

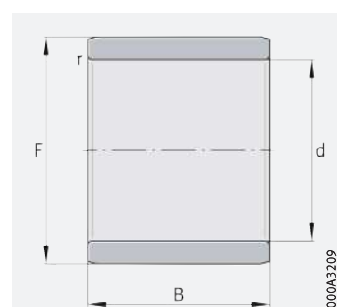

## Innenringe ohne Schmierbohrung



IR

### d = 5 – 25 mm

Hauptabmessungen				Masse m ≈ g	Kurzzeichen ▶ 983   3.5 ▶ 984   3.6 X-life ▶ 981	Abmaße der Laufbahn F	
d	F	B	r min.			oberes μm	unteres μm
5	8	12	0,3	2,8	<b>IR5×8×12-XL</b>	-7	-23
	8	16	0,3	3,7	<b>IR5×8×16-XL</b>	-7	-23
6	9	12	0,3	3	<b>IR6×9×12-XL</b>	-7	-23
	9	16	0,3	4,3	<b>IR6×9×16-XL</b>	-7	-23
7	10	10,5	0,3	3,1	<b>IR7×10×10,5-XL</b>	-7	-23
	10	12	0,3	3,6	<b>IR7×10×12-XL</b>	-7	-23
	10	16	0,3	4,9	<b>IR7×10×16-XL</b>	-7	-23
8	12	10,5	0,3	5	<b>IR8×12×10,5-XL</b>	-4	-18
	12	12,5	0,3	5,9	<b>IR8×12×12,5-XL</b>	-4	-18
9	12	12	0,3	4,4	<b>IR9×12×12-XL</b>	-4	-18
	12	16	0,3	6	<b>IR9×12×16-XL</b>	-4	-18
10	13	12,5	0,3	5,2	<b>IR10×13×12,5-XL</b>	-4	-18
	14	13	0,3	7,4	<b>IR10×14×13-XL</b>	-4	-18
	14	16	0,3	9,2	<b>IR10×14×16-XL</b>	-4	-18
	14	20	0,3	11,5	<b>IR10×14×20-XL</b>	-4	-18
12	15	12	0,3	5,7	<b>IR12×15×12-XL</b>	-4	-18
	15	12,5	0,3	6,1	<b>IR12×15×12,5-XL</b>	-4	-18
	15	16	0,3	7,6	<b>IR12×15×16-XL</b>	-4	-18
	15	16,5	0,3	8,1	<b>IR12×15×16,5-XL</b>	-4	-18
	15	22,5	0,3	10,9	<b>IR12×15×22,5-XL</b>	-4	-18
	16	13	0,3	8,5	<b>IR12×16×13-XL</b>	-4	-18
	16	16	0,3	10,7	<b>IR12×16×16-XL</b>	-4	-18
	16	20	0,3	13,5	<b>IR12×16×20-XL</b>	-4	-18
	16	22	0,3	14,9	<b>IR12×16×22-XL</b>	-4	-18
14	17	17	0,3	9,5	<b>IR14×17×17-XL</b>	-4	-18
15	18	16	0,3	9,4	<b>IR15×18×16-XL</b>	-4	-18
	18	16,5	0,3	9,8	<b>IR15×18×16,5-XL</b>	-4	-18
	19	16	0,3	12,9	<b>IR15×19×16-XL</b>	0	-12
	19	20	0,3	16,3	<b>IR15×19×20-XL</b>	0	-12
	20	13	0,3	13,5	<b>IR15×20×13-XL</b>	0	-12
	20	23	0,3	24,4	<b>IR15×20×23-XL</b>	0	-12

medias ▶ <https://www.schaeffler.de/std/1D08>



Hauptabmessungen				Masse m ≈ g	Kurzzzeichen ▶983 3.5 ▶984 3.6 X-life▶981	Abmaße der Laufbahn F	
d	F	B	r min.			oberes μm	unteres μm
17	20	16	0,3	10,6	<b>IR17×20×16-XL</b>	0	-12
	20	16,5	0,3	11,1	<b>IR17×20×16,5-XL</b>	0	-12
	20	20	0,3	13,5	<b>IR17×20×20-XL</b>	0	-12
	20	20,5	0,3	13,8	<b>IR17×20×20,5-XL</b>	0	-12
	20	30,5	0,3	20,6	<b>IR17×20×30,5-XL</b>	0	-12
	21	16	0,3	15	<b>IR17×21×16-XL</b>	0	-12
	21	20	0,3	18	<b>IR17×21×20-XL</b>	0	-12
	22	13	0,3	14,9	<b>IR17×22×13-XL</b>	0	-12
	22	16	0,3	18,4	<b>IR17×22×16-XL</b>	0	-12
	22	23	0,3	27,1	<b>IR17×22×23-XL</b>	0	-12
24	20	0,6	33,8	<b>IR17×24×20-XL</b>	0	-12	
20	24	16	0,3	15	<b>IR20×24×16-XL</b>	0	-12
	24	20	0,3	21,3	<b>IR20×24×20-XL</b>	0	-12
	25	17	0,3	25	<b>IR20×25×17-XL</b>	0	-12
	25	20	0,3	27,5	<b>IR20×25×20-XL</b>	0	-12
	25	20,5	0,3	27,4	<b>IR20×25×20,5-XL</b>	0	-12
	25	26,5	0,3	38	<b>IR20×25×26,5-XL</b>	0	-12
	25	30	0,3	40,4	<b>IR20×25×30-XL</b>	0	-12
	25	38,5	0,3	52,5	<b>IR20×25×38,5-XL</b>	0	-12
28	20	0,6	45,2	<b>IR20×28×20-XL</b>	0	-12	
22	26	16	0,3	18,2	<b>IR22×26×16-XL</b>	0	-12
	28	17	0,3	29,5	<b>IR22×28×17-XL</b>	0	-12
	26	20	0,3	23	<b>IR22×26×20-XL</b>	0	-12
	28	20	0,3	35	<b>IR22×28×20-XL</b>	0	-12
	28	20,5	0,3	36	<b>IR22×28×20,5-XL</b>	0	-12
	28	30	0,3	54,4	<b>IR22×28×30-XL</b>	0	-12
25	29	20	0,3	25,9	<b>IR25×29×20-XL</b>	0	-12
	29	30	0,3	39,3	<b>IR25×29×30-XL</b>	0	-12
	30	17	0,3	27,4	<b>IR25×30×17-XL</b>	0	-12
	30	20	0,3	32,8	<b>IR25×30×20-XL</b>	0	-12
	30	20,5	0,3	33,4	<b>IR25×30×20,5-XL</b>	0	-12
	30	26,5	0,3	46	<b>IR25×30×26,5-XL</b>	0	-12
	30	30	0,3	53	<b>IR25×30×30-XL</b>	0	-12
	30	32	0,3	56	<b>IR25×30×32-XL</b>	0	-12
	30	38,5	0,3	64,5	<b>IR25×30×38,5-XL</b>	0	-12
	32	22	0,6	52,5	<b>IR25×32×22-XL</b>	+5	-4

medias ▶ <https://www.schaeffler.de/std/1CBB>



## Innenringe ohne Schmierbohrung

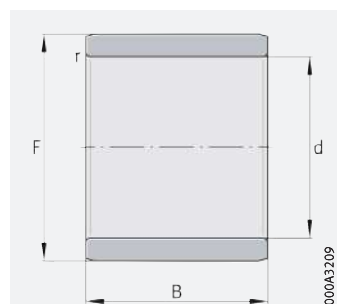

IR

### d = 28 – 70 mm

Hauptabmessungen				Masse m ≈ g	Kurzzeichen ▶ 983   3.5 ▶ 984   3.6 X-life ▶ 981	Abmaße der Laufbahn F	
d	F	B	r min.			oberes μm	unteres μm
<b>28</b>	32	17	0,3	24,5	<b>IR28×32×17-XL</b>	+5	-4
	32	20	0,3	28,5	<b>IR28×32×20-XL</b>	+5	-4
	32	30	0,3	43,5	<b>IR28×32×30-XL</b>	+5	-4
<b>30</b>	35	13	0,3	25	<b>IR30×35×13-XL</b>	+5	-4
	35	16	0,3	34	<b>IR30×35×16-XL</b>	+5	-4
	35	17	0,3	36	<b>IR30×35×17-XL</b>	+5	-4
	35	20	0,3	39	<b>IR30×35×20-XL</b>	+5	-4
	35	20,5	0,3	39,7	<b>IR30×35×20,5-XL</b>	+5	-4
	35	26	0,3	50,4	<b>IR30×35×26-XL</b>	+5	-4
	35	30	0,3	58,5	<b>IR30×35×30-XL</b>	+5	-4
	37	18	0,6	50	<b>IR30×37×18-XL</b>	+5	-4
<b>32</b>	37	22	0,6	61,6	<b>IR30×37×22-XL</b>	+5	-4
	37	20	0,3	42	<b>IR32×37×20-XL</b>	0	-9
	37	30	0,3	62	<b>IR32×37×30-XL</b>	0	-9
	40	20	0,6	68	<b>IR32×40×20-XL</b>	0	-9
<b>33</b>	40	36	0,6	124	<b>IR32×40×36-XL</b>	0	-9
	37	13	0,3	21,9	<b>IR33×37×13-XL</b>	0	-9
<b>35</b>	40	17	0,3	37,8	<b>IR35×40×17-XL</b>	0	-9
	40	20	0,3	44,2	<b>IR35×40×20-XL</b>	0	-9
	40	20,5	0,3	46,1	<b>IR35×40×20,5-XL</b>	0	-9
	40	30	0,3	67,1	<b>IR35×40×30-XL</b>	0	-9
	42	36	0,6	117,2	<b>IR35×42×36-XL</b>	0	-9
	43	22	0,6	82	<b>IR35×43×22-XL</b>	0	-9
<b>38</b>	43	20	0,3	48,1	<b>IR38×43×20-XL</b>	0	-9
	43	30	0,3	73,6	<b>IR38×43×30-XL</b>	0	-9
<b>40</b>	45	17	0,3	42,5	<b>IR40×45×17-XL</b>	0	-9
	45	20	0,3	50,8	<b>IR40×45×20-XL</b>	0	-9
	45	20,5	0,3	51,8	<b>IR40×45×20,5-XL</b>	0	-9
	45	30	0,3	84	<b>IR40×45×30-XL</b>	0	-9
	48	22	0,6	91,6	<b>IR40×48×22-XL</b>	0	-9
	48	40	0,6	170	<b>IR40×48×40-XL</b>	0	-9
	50	22	1	118	<b>IR40×50×22-XL</b>	0	-9
<b>42</b>	47	20	0,3	52,8	<b>IR42×47×20-XL</b>	-5	-19
	47	30	0,3	81	<b>IR42×47×30-XL</b>	-5	-19

medias ▶ <https://www.schaeffler.de/std/1BE9>



Hauptabmessungen				Masse m ≈ g	Kurzzeichen ▶ 983   3.5 ▶ 984   3.6 X-life ▶ 981	Abmaße der Laufbahn F	
d	F	B	r min.			oberes μm	unteres μm
45	50	25	0,6	70,8	<b>IR45×50×25-XL</b>	-5	-19
	50	25,5	0,3	75,1	<b>IR45×50×25,5-XL</b>	-5	-19
	50	35	0,6	101	<b>IR45×50×35-XL</b>	-5	-19
	52	22	0,6	89	<b>IR45×52×22-XL</b>	0	-11
	52	40	0,6	164	<b>IR45×52×40-XL</b>	0	-11
	55	22	1	129	<b>IR45×55×22-XL</b>	0	-11
50	55	25	0,6	78	<b>IR50×55×25-XL</b>	0	-11
	55	35	0,6	112	<b>IR50×55×35-XL</b>	0	-11
	58	22	0,6	115	<b>IR50×58×22-XL</b>	0	-11
	58	40	0,6	208	<b>IR50×58×40-XL</b>	0	-11
	60	25	1	162	<b>IR50×60×25-XL</b>	0	-11
	60	28	1,1	181	<b>IR50×60×28-XL</b>	0	-11
55	60	25	0,6	85,5	<b>IR55×60×25-XL</b>	-10	-21
	60	35	0,6	121	<b>IR55×60×35-XL</b>	-10	-21
	63	25	1	141	<b>IR55×63×25-XL</b>	-10	-21
	63	45	1	256	<b>IR55×63×45-XL</b>	-10	-21
	65	28	1,1	198	<b>IR55×65×28-XL</b>	-10	-21
60	68	25	1	152	<b>IR60×68×25-XL</b>	-10	-21
	68	35	0,6	213	<b>IR60×68×35-XL</b>	-10	-21
	68	45	1	276	<b>IR60×68×45-XL</b>	-10	-21
	70	25	1	195	<b>IR60×70×25-XL</b>	-10	-21
	70	28	1,1	215	<b>IR60×70×28-XL</b>	-10	-21
65	72	25	1	141	<b>IR65×72×25-XL</b>	-10	-21
	72	45	1	259	<b>IR65×72×45-XL</b>	-10	-21
	73	25	1	164	<b>IR65×73×25-XL</b>	-10	-21
	73	35	1	231	<b>IR65×73×35-XL</b>	-10	-21
	75	28	1,1	229	<b>IR65×75×28-XL</b>	-10	-21
70	80	25	1	221	<b>IR70×80×25-XL</b>	-10	-26
	80	30	1	267	<b>IR70×80×30-XL</b>	-10	-26
	80	35	1	312	<b>IR70×80×35-XL</b>	-10	-26
	80	54	1	488	<b>IR70×80×54-XL</b>	-10	-26

medias ▶ <https://www.schaeffler.de/std/1C52>





## Innenringe ohne Schmierbohrung

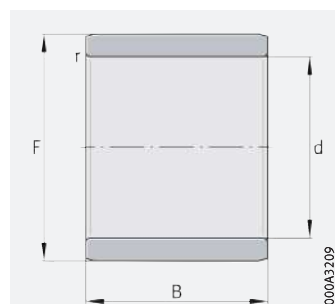

IR

### d = 75 – 380 mm

Hauptabmessungen				Masse m ≈ g	Kurzzeichen ►983 3.5 ►984 3.6 X-life ►981	Abmaße der Laufbahn F	
d	F	B	r min.			oberes μm	unteres μm
<b>75</b>	85	25	1	238	<b>IR75×85×25-XL</b>	-4	-17
	85	30	1	287	<b>IR75×85×30-XL</b>	-4	-17
	85	35	1	336	<b>IR75×85×35-XL</b>	-4	-17
	85	54	1	520	<b>IR75×85×54-XL</b>	-4	-17
<b>80</b>	90	25	1	253	<b>IR80×90×25-XL</b>	-4	-17
	90	30	1	304	<b>IR80×90×30-XL</b>	-4	-17
	90	35	1	355	<b>IR80×90×35-XL</b>	-4	-17
	90	54	1	556	<b>IR80×90×54-XL</b>	-4	-17
<b>85</b>	95	26	1	277	<b>IR85×95×26-XL</b>	-14	-27
	95	36	1	388	<b>IR85×95×36-XL</b>	-14	-27
	100	35	1,1	582	<b>IR85×100×35-XL</b>	-14	-27
	100	63	1,1	1 054	<b>IR85×100×63-XL</b>	-14	-27
<b>90</b>	100	26	1	294	<b>IR90×100×26-XL</b>	-14	-27
	100	30	1	340	<b>IR90×100×30-XL</b>	-14	-27
	100	36	1	406	<b>IR90×100×36-XL</b>	-14	-27
	105	35	1,1	610	<b>IR90×105×35-XL</b>	-14	-27
	105	63	1,1	1 110	<b>IR90×105×63-XL</b>	-14	-27
<b>95</b>	105	26	1	313	<b>IR95×105×26-XL</b>	-14	-27
	105	36	1	431	<b>IR95×105×36-XL</b>	-14	-27
	110	35	1,1	657	<b>IR95×110×35-XL</b>	-14	-27
	110	63	1,1	1 170	<b>IR95×110×63-XL</b>	-14	-27
<b>100</b>	110	30	1,1	350	<b>IR100×110×30-XL</b>	-14	-27
	110	40	1,1	505	<b>IR100×110×40-XL</b>	-14	-27
	115	40	1,1	797	<b>IR100×115×40-XL</b>	-14	-27
<b>110</b>	120	30	1	409	<b>IR110×120×30-XL</b>	-14	-32
	125	40	1,1	840	<b>IR110×125×40-XL</b>	-7	-22
<b>120</b>	130	30	1	442	<b>IR120×130×30-XL</b>	-7	-22
	135	45	1,1	1 044	<b>IR120×135×45-XL</b>	-7	-22
<b>130</b>	145	35	1,1	855	<b>IR130×145×35-XL</b>	-17	-37
	150	50	1,5	1 690	<b>IR130×150×50-XL</b>	-17	-37
<b>140</b>	155	35	1,1	917	<b>IR140×155×35-XL</b>	-17	-37
	160	50	1,5	1 800	<b>IR140×160×50-XL</b>	-17	-37

medias ► <https://www.schaeffler.de/std/1B87>



Hauptabmessungen				Masse m ≈ g	Kurzzeichen ▶ 983   3.5 ▶ 984   3.6 X-life ▶ 981	Abmaße der Laufbahn F	
d	F	B	r min.			oberes μm	unteres μm
150	165	40	1,1	1 122	<b>IR150×165×40-XL</b>	-27	-52
160	175	40	1,1	1 200	<b>IR160×175×40-XL</b>	-27	-52
170	185	45	1,1	1 441	<b>IR170×185×45-XL</b>	-25	-46
180	195	45	1,1	1 510	<b>IR180×195×45-XL</b>	-25	-46
190	210	50	1,5	2 410	<b>IR190×210×50-XL</b>	-40	-66
200	220	50	1,5	2 518	<b>IR200×220×50-XL</b>	-40	-66
220	240	50	1,5	2 753	<b>IR220×240×50-XL</b>	-55	-86
240	265	60	2	4 600	<b>IR240×265×60-XL</b>	-55	-86
260	285	60	2	4 980	<b>IR260×285×60-XL</b>	-69	-107
280	305	69	2	6 100	<b>IR280×305×69-XL</b>	-69	-107
300	330	80	2,1	9 200	<b>IR300×330×80-XL</b>	-69	-107
320	350	80	2,1	9 800	<b>IR320×350×80-XL</b>	-83	-127
340	370	80	2,1	10 200	<b>IR340×370×80-XL</b>	-83	-127
360	390	80	2,1	10 900	<b>IR360×390×80-XL</b>	-128	-182
380	415	100	2,1	16 700	<b>IR380×415×100-XL</b>	-122	-172

medias ▶ <https://www.schaeffler.de/std/1CBD>



## Innenringe mit Schmierbohrung

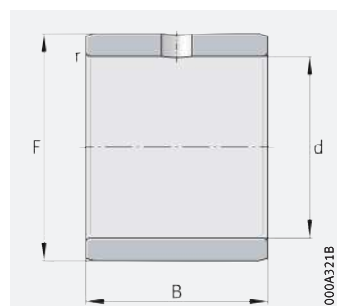

IR..-IS1

### d = 6 – 50 mm

Hauptabmessungen				Masse m ≈ g	Kurzzeichen ▶ 983   3.5 ▶ 984   3.6 X-life ▶ 981	Abmaße der Laufbahn F	
d	F	B	r min.			oberes μm	unteres μm
6	10	10	0,3	3,7	<b>IR6×10×10-IS1-XL</b>	-7	-23
8	12	10	0,3	4,8	<b>IR8×12×10-IS1-XL</b>	-4	-18
10	14	12	0,3	7,3	<b>IR10×14×12-IS1-XL</b>	-4	-18
12	16	12	0,3	7,9	<b>IR12×16×12-IS1-XL</b>	-4	-18
15	20	12	0,3	12,2	<b>IR15×20×12-IS1-XL</b>	0	-12
20	25	16	0,3	24	<b>IR20×25×16-IS1-XL</b>	0	-12
25	30	16	0,3	25,7	<b>IR25×30×16-IS1-XL</b>	0	-12
30	38	20	0,6	77	<b>IR30×38×20-IS1-XL</b>	+5	-4
35	42	20	0,6	63,9	<b>IR35×42×20-IS1-XL</b>	0	-9
40	50	20	1	106	<b>IR40×50×20-IS1-XL</b>	0	-9
45	55	20	1	117	<b>IR45×55×20-IS1-XL</b>	0	-11
50	55	20	0,6	62,5	<b>IR50×55×20-IS1-XL</b>	0	-11
	60	20	1	128	<b>IR50×60×20-IS1-XL</b>	0	-11

medias ▶ <https://www.schaeffler.de/std/1C58>