

WITRA®	DIN/ISO	Teilung		Innere Breite	Innengliedbreite	Rollen-Ø	Bolzen-Ø	Laschenhöhe	Überstand	Maß über Bolzen	Gelenkfläche	Bruchkraft DIN	Gewicht	Verbindungsglieder
		Pitch		Inner width	Inner link width	Roller-Ø	Pin-Ø	Plate height	Project. over conn. link	Width over pin	Bearing area	Breaking load DIN	Weight	Connecting links
		p		b ₁ min.	b ₂ max.	d ₁ min.	d ₂ max.	g max.	k max.	l ₁ max.	f	F _B min.	q ≈	
No.	No.	mm	inch	mm	mm	mm	mm	mm	mm	mm	cm ²	N	kg/m	Type
WT 04	04	6	-	2,80	4,10	4,00	1,85	5,1	2,9	7,4	0,08	3 000	0,11	A, E, C
WT 05	05 B-1	8	-	3,00	4,77	5,00	2,31	7,1	3,1	8,6	0,11	5 000	0,18	A, E, C
WT 06	06 B-1	9,525	3/8	5,72	8,53	6,35	3,28	8,2	3,3	13,5	0,28	9 000	0,39	A, E, L, C
WT 08	08 B-1	12,7	1/2	7,75	11,30	8,51	4,45	11,8	3,9	17,0	0,50	18 000	0,68	A, E, L, C
WT 081	081	12,7	1/2	3,30	5,80	7,75	3,66	9,9	1,5	10,2	0,21	8 200	0,28	A, E, L
WT 083	083	12,7	1/2	4,88	7,90	7,75	4,09	10,3	1,5	10,6	0,32	12 000	0,42	A, E, L
WT 084	084	12,7	1/2	4,88	8,80	7,75	4,09	11,1	1,5	11,5	0,36	16 000	0,59	A, E, L
WT 10	10 B-1	15,875	5/8	9,65	13,28	10,16	5,08	14,7	4,1	19,6	0,67	22 400	0,91	A, E, L, C
WT 12	12 B-1	19,05	3/4	11,68	15,62	12,07	5,72	16,1	4,6	22,7	0,89	29 000	1,12	A, E, S, L, C
WT 12-H	12 B-H	19,05	3/4	11,68	16,46	12,07	6,05	18,1	3,6	24,8	1,05	40 000	1,51	A, E, S, L
WT 16	16 B-1	25,4	1	17,02	25,40	15,88	8,28	21,0	5,4	36,1	2,10	60 000	2,64	A, E, S, L, C
WT 20	20 B-1	31,75	1 1/4	19,56	29,00	19,05	10,19	26,4	6,1	43,2	2,96	95 000	3,68	A, E, S, L
WT 24	24 B-1	38,1	1 1/2	25,40	37,90	25,40	14,63	33,4	6,6	53,4	5,54	160 000	7,16	A, S, L, C
WT 28	28 B-1	44,45	1 3/4	30,99	46,50	27,94	15,90	37,0	7,4	65,1	7,39	200 000	7,53	A, S, L, C
WT 32	32 B-1	50,8	2	30,99	45,50	29,21	17,81	42,2	7,9	67,4	8,10	250 000	9,84	A, S, L, C
WT 40	40 B-1	63,5	2 1/2	38,10	55,70	39,37	22,89	52,9	10,0	82,6	12,75	355 000	16,99	A, S, L
WT 48	48 B-1	76,2	3	45,72	70,50	48,26	29,24	63,8	10,0	99,1	20,61	560 000	23,92	A, S, L
WT 56	56 B-1	88,9	3 1/2	53,34	81,30	53,98	34,32	77,8	11,7	114,6	27,90	850 000	35,78	A, S, L

Verbindungsglieder / Connecting links

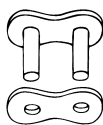

A

Außenglied
(Nietglied)

Pin link

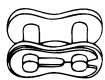

E

Verbindungsglied
mit Feder

Spring
Connecting link

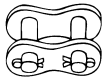

S

Verbindungsglied
mit Splinten

Cotter pin
Connecting link



L

Gekröpftes Glied
mit Splint

Offset link



C

Gekröpftes
Doppelglied

Double
cranked link

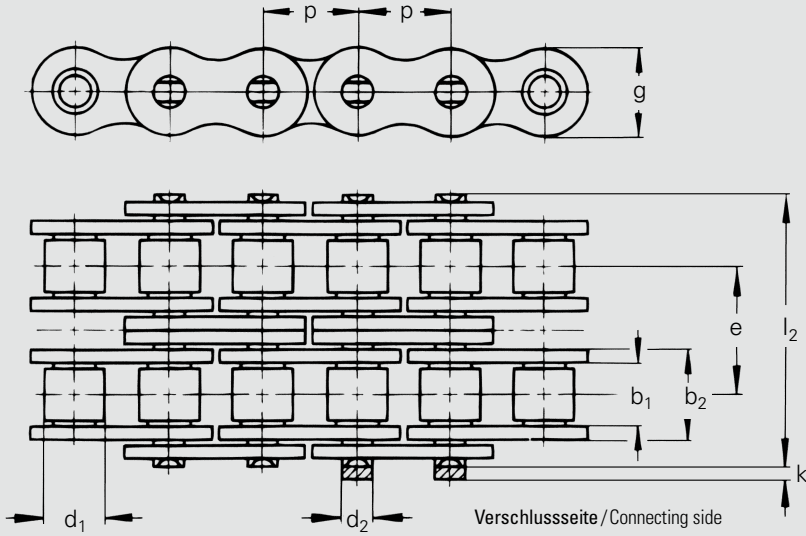

WITRA [®]	DIN/ISO	Teilung		Innere Breite	Innengliedbreite	Rollen-Ø	Bolzen-Ø	Querteilung	Laschenhöhe	Überstand	Maß über Bolzen	Gelenkfläche	Bruchkraft DIN	Gewicht	Verbindungsglieder
		Pitch		Inner width	Inner link width	Roller-Ø	Pin-Ø	Transverse pitch	Plate height	Project. over conn. link	Width over pin	Bearing area	Breaking load DIN	Weight	Connecting links
		p		b ₁ min.	b ₂ max.	d ₁ min.	d ₂ max.	e max.	g max.	k max.	l ₂ max.	f	F _B min.	q ≈	
No.	No.	mm	inch	mm	mm	mm	mm	mm	mm	mm	mm	cm ²	N	kg/m	Type
WT 05-D	05 B-2	8	-	3,00	4,77	5,00	2,31	5,64	7,1	3,1	14,3	0,22	7 800	0,34	A, E, C
WT 06-D	06 B-2	9,525	3/8	5,72	8,53	6,35	3,28	10,24	8,2	3,3	23,8	0,56	16 900	0,74	A, E, L, C
WT 08-D	08 B-2	12,7	1/2	7,75	11,30	8,51	4,45	13,92	11,8	3,9	31,0	1,01	32 000	1,35	A, E, L, C
WT 10-D	10 B-2	15,875	5/8	9,65	13,28	10,16	5,08	16,59	14,7	4,1	36,2	1,34	44 500	1,79	A, E, S, L, C
WT 12-D	12 B-2	19,05	3/4	11,68	15,62	12,07	5,72	19,46	16,1	4,6	42,2	1,79	57 800	2,22	A, E, S, L, C
WT 16-D	16 B-2	25,4	1	17,02	25,40	15,88	8,28	31,88	21,0	5,4	68,0	4,21	106 000	5,13	A, E, S, L, C
WT 20-D	20 B-2	31,75	1 1/4	19,56	29,00	19,05	10,19	36,45	26,4	6,1	79,0	5,91	170 000	7,72	A, E, S, L, C
WT 24-D	24 B-2	38,1	1 1/2	25,40	37,90	25,40	14,63	48,36	33,4	6,6	101,4	11,09	280 000	14,15	A, E, L, C
WT 28-D	28 B-2	44,45	1 3/4	30,99	46,50	27,94	15,90	59,56	37,0	7,4	124,0	14,79	360 000	14,91	A, E, L, C
WT 32-D	32 B-2	50,8	2	30,99	45,50	29,21	17,81	58,55	42,2	7,9	126,0	16,21	450 000	19,68	A, E, L, C
WT 40-D	40 B-2	63,5	2 1/2	38,10	55,70	39,37	22,89	72,29	52,9	10,0	154,0	25,50	630 000	33,61	A, S, L
WT 48-D	48 B-2	76,2	3	45,72	70,50	48,26	29,24	91,21	63,8	10,0	190,4	41,23	1 000 000	47,50	A, S, L
WT 56-D	56 B-2	88,9	3 1/2	53,34	81,30	53,98	34,32	106,60	77,8	11,7	221,2	55,80	1 600 000	71,48	A, S, L

Verbindungsglieder / Connecting links

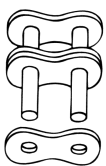

A

Außenglied
(Nietglied)

Pin link



E

Verbindungsglied
mit Feder

Spring
Connecting link

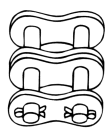

S

Verbindungsglied
mit Splinten

Cotter pin
Connecting link



L

Gekröpftes Glied
mit Splint

Offset link

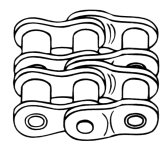

C

Gekröpftes
Doppelglied

Double
cranked link

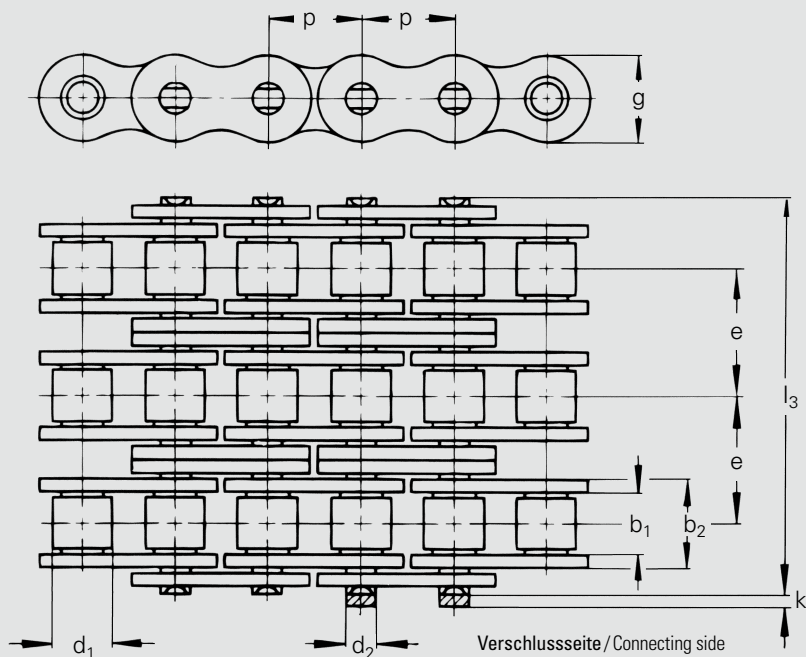

WITRA®	DIN/ISO	Teilung	Innere Breite	Innengliedbreite	Rollen-Ø	Bolzen-Ø	Quer-teilung	Laschen-höhe	Über-stand	Maß über Bolzen	Gelenk-fläche	Bruchkraft DIN	Gewicht	Verbindungs-glieder	
		Pitch	Inner width	Inner link width	Roller-Ø	Pin-Ø	Transverse pitch	Plate height	Project. over conn. link	Width over pin	Bearing area	Breaking load DIN	Weight	Connecting links	
		p	b_1 min.	b_2 max.	d_1 min.	d_2 max.	e max.	g max.	k max.	l_3 max.	f	F_B min.	q ≈	Type	
No.	No.	mm	inch	mm	mm	mm	mm	mm	mm	mm	cm ²	N	kg/m		
WT 06-T	06 B-3	9,525	3/8	5,72	8,53	6,35	3,28	10,24	8,2	3,3	34,0	0,81	23 600	1,10	A, E, L, C
WT 08-T	08 B-3	12,7	1/2	7,75	11,30	8,51	4,45	13,92	11,8	3,9	44,9	1,51	47 500	2,03	A, E, L, C
WT 10-T	10 B-3	15,875	5/8	9,65	13,28	10,16	5,08	16,59	14,7	4,1	52,8	2,02	66 700	2,68	A, E, S, L, C
WT 12-T	12 B-3	19,05	3/4	11,68	15,62	12,07	5,72	19,46	16,1	4,6	61,7	2,68	86 700	3,39	A, E, S, L, C
WT 16-T	16 B-3	25,4	1	17,02	25,40	15,88	8,28	31,88	21,0	5,4	99,9	6,31	160 000	7,80	A, E, S, L, C
WT 20-T	20 B-3	31,75	1 1/4	19,56	29,00	19,05	10,19	36,45	26,4	6,1	116,0	8,87	250 000	11,53	A, S, L, C
WT 24-T	24 B-3	38,1	1 1/2	25,40	37,90	25,40	14,63	48,36	33,4	6,6	150,0	16,63	425 000	21,15	A, S, L, C
WT 28-T	28 B-3	44,45	1 3/4	30,99	46,50	27,94	15,90	59,56	37,0	7,4	184,0	22,18	530 000	22,39	A, S, L, C
WT 32-T	32 B-3	50,8	2	30,99	45,50	29,21	17,81	58,55	42,2	7,9	184,0	24,31	670 000	29,52	A, S, L, C
WT 40-T	40 B-3	63,5	2 1/2	38,10	55,70	39,37	22,89	72,29	52,9	10,0	227,0	38,25	950 000	50,23	A, S, L
WT 48-T	48 B-3	76,2	3	45,72	70,50	48,26	29,24	91,21	63,8	10,0	281,0	61,84	1 500 000	71,07	A, S, L
WT 56-T	56 B-3	88,9	3 1/2	53,34	81,30	53,98	34,32	106,60	77,8	11,7	327,8	83,70	2 240 000	107,18	A, S, L

Verbindungsglieder / Connecting links

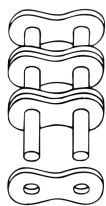

A

Außenglied (Nietglied)

Pin link

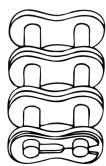

E

Verbindungsglied mit Feder

Spring Connecting link

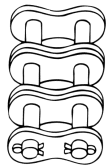

S

Verbindungsglied mit Splinten

Cotter pin Connecting link



L

Gekröpftes Glied mit Splint

Offset link

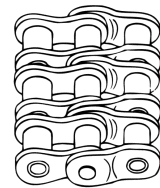

C

Gekröpftes Doppelglied

Double cranked link

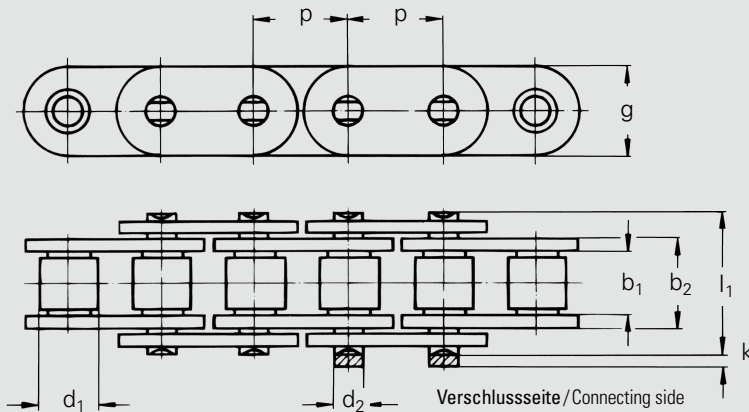

WITRA [®]	DIN/ISO	Teilung		Innere Breite	Innengliedbreite	Rollen-Ø	Bolzen-Ø	Laschenhöhe	Überstand	Maß über Bolzen	Gelenkfläche	Bruchkraft DIN	Gewicht	Verbindungsglieder
		Pitch		Inner width	Inner link width	Roller-Ø	Pin-Ø	Plate height	Project. over conn. link	Width over pin	Bearing area	Breaking load DIN	Weight	Connecting links
		p		b ₁ min.	b ₂ max.	d ₁ min.	d ₂ max.	g max.	k max.	l ₁ max.	f	F _B min.	q ≈	
No.	No.	mm	inch	mm	mm	mm	mm	mm	mm	mm	cm ²	N	kg/m	Type
WT C 06	C 06 B-1	9,525	3/8	5,72	8,53	6,35	3,28	8,2	3,3	13,5	0,28	9 000	0,39	A, E, L
WT C 08	C 08 B-1	12,7	1/2	7,75	11,30	8,51	4,45	11,8	3,9	17,0	0,50	18 000	0,68	A, E, L
WT C 10	C 10 B-1	15,875	5/8	9,65	13,28	10,16	5,08	14,7	4,1	19,6	0,67	22 400	0,91	A, E, L
WT C 12	C 12 B-1	19,05	3/4	11,68	15,62	12,07	5,72	16,1	4,6	22,7	0,89	29 000	1,12	A, E, L
WT C 16	C 16 B-1	25,4	1	17,02	25,40	15,88	8,28	21,0	5,4	36,1	2,10	60 000	2,64	A, E, S, L
WT C 16/24	-	25,4	1	17,02	25,40	15,88	8,28	24,0	5,4	36,1	2,10	60 000	2,64	A, E, S, L
WT C 20	C 20 B-1	31,75	1 1/4	19,56	29,00	19,05	10,19	26,4	6,1	43,2	2,96	95 000	3,68	A, E, S, L
WT C 24	C 24 B-1	38,1	1 1/2	25,40	37,90	25,40	14,63	33,4	6,6	53,4	5,54	160 000	7,16	A, S, L
WT C 32	C 32 B-1	50,8	2	30,99	45,50	29,21	17,81	42,2	7,9	67,4	8,10	250 000	9,84	A, S, L

Verbindungsglieder / Connecting links

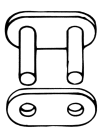

A

Außenglied
(Nietglied)

Pin link

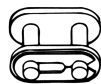

E

Verbindungsglied
mit Feder

Spring
Connecting link



S

Verbindungsglied
mit Splinten

Cotter pin
Connecting link



L

Gekröpftes Glied
mit Splint

Offset link

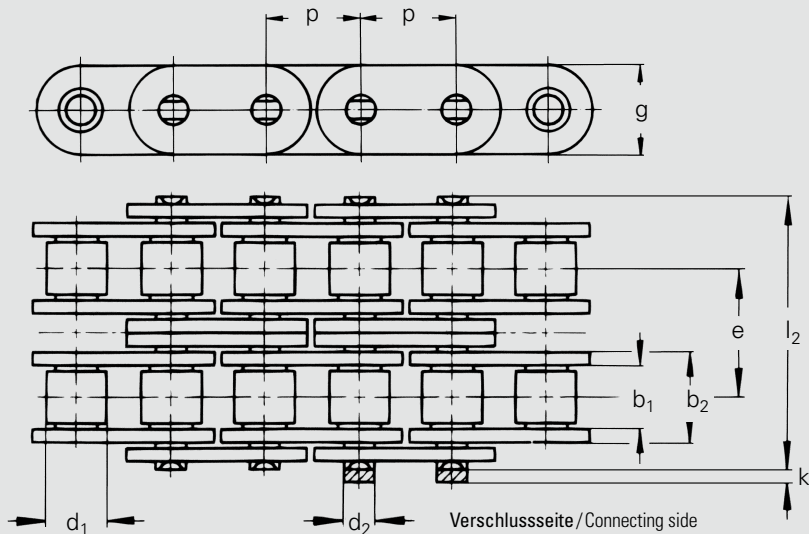

WITRA®	DIN/ISO	Teilung		Innere Breite	Innengliedbreite	Rollen-Ø	Bolzen-Ø	Querteilung	Laschenhöhe	Überstand	Maß über Bolzen	Gelenkfläche	Bruchkraft DIN	Gewicht	Verbindungsglieder
		Pitch		Inner width	Inner link width	Roller-Ø	Pin-Ø	Transverse pitch	Plate height	Project. over conn. link	Width over pin	Bearing area	Breaking load DIN	Weight	Connecting links
		p		b ₁ min.	b ₂ max.	d ₁ min.	d ₂ max.	e max.	g max.	k max.	l ₂ max.	f	F _B min.	q ≈	
No.	No.	mm	inch	mm	mm	mm	mm	mm	mm	mm	mm	cm ²	N	kg/m	Type
WT C 06-D	C 06 B-2	9,525	3/8	5,72	8,53	6,35	3,28	10,24	8,2	3,3	23,8	0,56	16 900	0,74	A, E, L
WT C 08-D	C 08 B-2	12,7	1/2	7,75	11,30	8,51	4,45	13,92	11,8	3,9	31,0	1,01	32 000	1,35	A, E, L
WT C 10-D	C 10 B-2	15,875	5/8	9,65	13,28	10,16	5,08	16,59	14,7	4,1	36,2	1,34	44 500	1,79	A, E, L
WT C 12-D	C 12 B-2	19,05	3/4	11,68	15,62	12,07	5,72	19,46	16,1	4,6	42,2	1,79	57 800	2,22	A, E, S, L
WT C 16-D	C 16 B-2	25,4	1	17,02	25,40	15,88	8,28	31,88	21,0	5,4	68,0	4,21	106 000	5,13	A, E, S, L
WT C 20-D	C 20 B-2	31,75	1 1/4	19,56	29,00	19,05	10,19	36,45	26,4	6,1	79,0	5,91	170 000	7,72	A, S, L
WT C 24-D	C 24 B-2	38,1	1 1/2	25,40	37,90	25,40	14,63	48,36	33,4	6,6	101,4	11,09	280 000	14,15	A, S, L
WT C 32-D	C 32 B-2	50,8	2	31,55	45,00	28,58	14,27	58,55	48,2	7,9	124,0	12,84	453 600	19,00	A, S, L

Verbindungsglieder / Connecting links

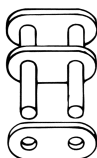

A

Außenglied
(Nietglied)

Pin link



E

Verbindungsglied
mit Feder

Spring
Connecting link



S

Verbindungsglied
mit Splinten

Cotter pin
Connecting link



L

Gekröpftes Glied
mit Splint

Offset link

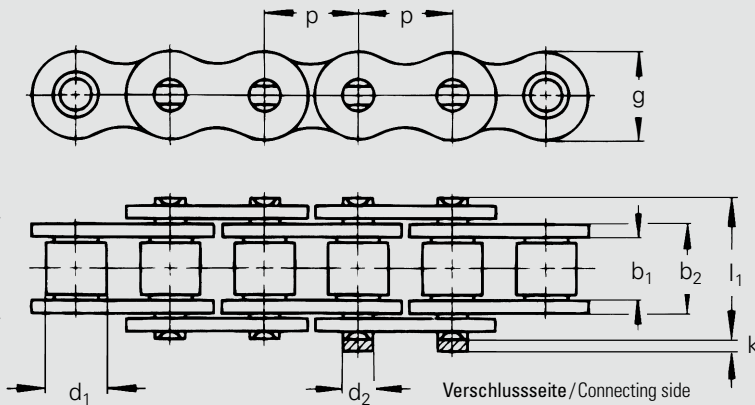

WITRA [®]	DIN/ISO	Teilung		Innere Breite	Innen-glied-breite	Rollen-Ø	Bolzen-Ø	Laschen-höhe	Über-stand	Maß über Bolzen	Gelenk-fläche	Bruchkraft DIN	Gewicht	Verbindungs-glieder
		Pitch		Inner width	Inner link width	Roller-Ø	Pin-Ø	Plate height	Project. over conn. link	Width over pin	Bearing area	Breaking load DIN	Weight	Connecting links
		p		b ₁ min.	b ₂ max.	d ₁ min.	d ₂ max.	g max.	k max.	l ₁ max.	f	F _B min.	q ≈	
No.	No.	mm	inch	mm	mm	mm	mm	mm	mm	mm	cm ²	N	kg/m	Type
WT ASA 40	08 A-1	12,7	1/2	7,85	11,15	7,95	3,96	12,0	3,9	17,8	0,44	14 100	0,60	A, E, L, C
WT ASA 50	10 A-1	15,875	5/8	9,40	13,80	10,16	5,08	15,0	4,1	21,8	0,70	22 200	1,04	A, E, L, C
WT ASA 60	12 A-1	19,05	3/4	12,57	17,70	11,91	5,94	18,0	4,6	26,9	1,05	31 800	1,52	A, E, L, C
WT ASA 80	16 A-1	25,4	1	15,75	22,50	15,88	7,92	24,1	5,4	33,5	1,78	56 700	2,60	A, E, L, C
WT ASA 100	20 A-1	31,75	1 1/4	18,90	27,40	19,05	9,53	30,1	6,1	41,1	2,61	88 500	4,01	A, S, L
WT ASA 120	24 A-1	38,1	1 1/2	25,22	35,30	22,23	11,10	36,2	6,6	50,8	3,92	127 000	5,74	A, S, L
WT ASA 140	28 A-1	44,45	1 3/4	25,22	37,00	25,40	12,70	42,2	7,4	54,9	4,70	172 400	7,66	A, S, L
WT ASA 160	32 A-1	50,8	2	31,55	45,00	28,58	14,27	48,2	7,9	65,5	6,42	226 800	9,84	A, S, L

Verbindungsglieder / Connecting links

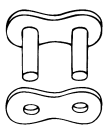

A

Außenglied
(Nietglied)

Pin link

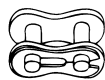

E

Verbindungsglied
mit Feder

Spring
Connecting link



S

Verbindungsglied
mit Splinten

Cotter pin
Connecting link



L

Gekröpftes Glied
mit Splint

Offset link



C

Gekröpftes
Doppelglied

Double
cranked link

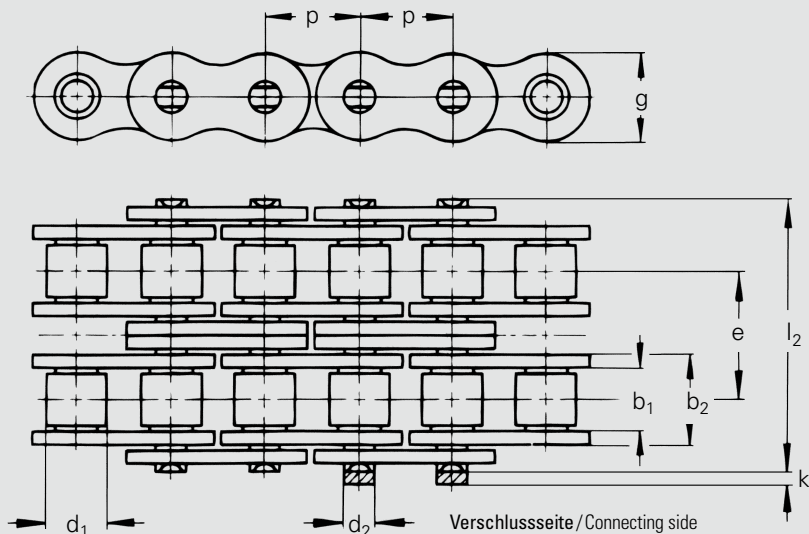

WITRA®	DIN / ISO	Teilung		Innere Breite	Innengliedbreite	Roller-Ø	Bolzen-Ø	Quer- teilung	Laschen- höhe	Über- stand	Maß über Bolzen	Gelenk- fläche	Bruchkraft DIN	Gewicht	Verbindungs- glieder
		Pitch		Inner width	Inner link width	Roller- Ø	Pin- Ø	Trans- verse pitch	Plate height	Project. over conn. link	Width over pin	Bear- ing area	Breaking load DIN	Weight	Connecting links
		p		b ₁ min.	b ₂ max.	d ₁ min.	d ₂ max.	e	g max.	k max.	l ₂ max.	f	F _B min.	q ≈	
No.	No.	mm	inch	mm	mm	mm	mm	mm	mm	mm	mm	cm ²	N	kg/m	Type
WT ASA 40-D	08 A-2	12,7	1/2	7,85	11,15	7,95	3,96	14,38	12,0	3,9	32,3	0,88	28 200	1,20	A, E, L, C
WT ASA 50-D	10 A-2	15,875	5/8	9,40	13,80	10,16	5,08	18,11	15,0	4,1	39,9	1,40	44 400	1,78	A, E, L, C
WT ASA 60-D	12 A-2	19,05	3/4	12,57	17,70	11,91	5,94	22,78	18,0	4,6	49,8	2,10	63 600	3,01	A, E, L, C
WT ASA 80-D	16 A-2	25,4	1	15,75	22,50	15,88	7,92	29,29	24,1	5,4	62,7	3,56	113 400	5,15	A, E, L, C
WT ASA 100-D	20 A-2	31,75	1 1/4	18,90	27,40	19,05	9,53	35,76	30,1	6,1	77,0	5,22	177 000	7,93	A, S, L
WT ASA 120-D	24 A-2	38,1	1 1/2	25,22	35,30	22,23	11,10	45,44	36,2	6,6	96,3	7,84	254 000	11,37	A, S, L
WT ASA 140-D	28 A-2	44,45	1 3/4	25,22	37,00	25,40	12,70	48,87	42,2	7,4	103,6	9,40	344 800	15,36	A, S, L
WT ASA 160-D	32 A-2	50,8	2	31,55	45,00	28,58	14,27	58,55	48,2	7,9	124,2	12,84	453 600	19,53	A, S, L

Verbindungsglieder / Connecting links

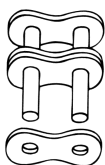

A

Außenglied
(Nietglied)

Pin link

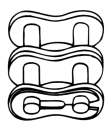

E

Verbindungsglied
mit Feder

Spring
Connecting link

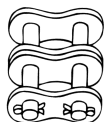

S

Verbindungsglied
mit Splinten

Cotter pin
Connecting link



L

Gekröpftes Glied
mit Splint

Offset link

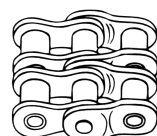

C

Gekröpftes
Doppelglied

Double
cranked link

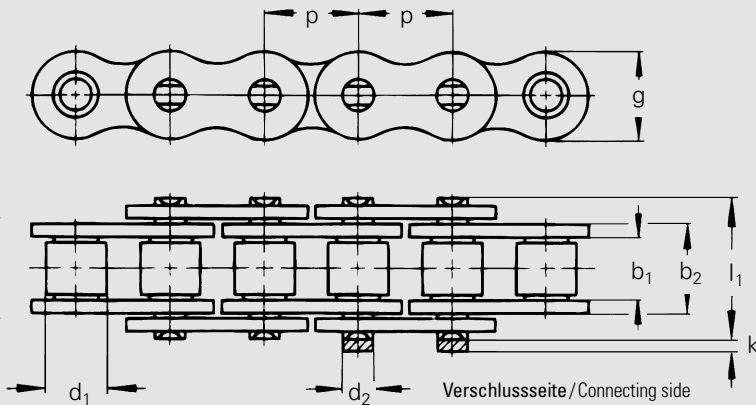

WITRA [®]	Teilung		Innere Breite	Innengliedbreite	Rollen-Ø	Bolzen-Ø	Laschenhöhe	Überstand	Maß über Bolzen	Gelenkfläche	Bruchkraft DIN	Gewicht	Verbindungsglieder
	Pitch		Inner width	Inner link width	Roller-Ø	Pin-Ø	Plate height	Project. over conn. link	Width over pin	Bearing area	Breaking load DIN	Weight	Connecting links
	p		b ₁ min.	b ₂ max.	d ₁ min.	d ₂ max.	g max.	k max.	l ₁ max.	f	F _B min.	q ≈	
No.	mm	inch	mm	mm	mm	mm	mm	mm	mm	cm ²	N	kg/m	Type
WT ASA 60-H	19,05	¾	12,57	19,43	11,91	5,96	18,1	4,6	30,2	1,16	31 300	1,81	A, E, L
WT ASA 80-H	25,4	1	15,75	24,28	15,88	7,94	24,1	5,4	37,4	1,92	55 600	3,00	A, S, L
WT ASA 100-H	31,75	1¼	18,90	29,10	19,05	9,54	30,2	6,1	44,5	2,77	87 000	4,38	A, S, L
WT ASA 120-H	38,1	1½	25,22	37,18	22,23	11,11	36,2	6,6	55,0	4,13	125 000	6,61	A, S, L
WT ASA 140-H	44,45	1¾	25,22	38,86	25,40	12,71	42,2	7,4	59,0	4,94	170 000	8,33	A, S, L
WT ASA 160-H	50,8	2	31,55	46,88	28,58	14,29	48,3	7,9	69,4	6,70	223 000	10,88	A, S, L
WT ASA 60-HGL	19,05	¾	12,57	19,43	11,91	5,96	18,1	4,6	30,2	1,16	31 300	1,81	A, E, L
WT ASA 80-HGL	25,4	1	15,75	24,28	15,88	7,94	24,1	5,4	37,4	1,92	55 600	3,00	A, E, L

Verbindungsglieder / Connecting links

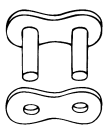

A

Außenglied
(Nietglied)

Pin link

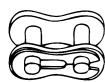

E

Verbindungsglied
mit Feder

Spring
Connecting link

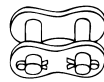

S

Verbindungsglied
mit Splinten

Cotter pin
Connecting link



L

Gekrüpfes Glied
mit Splint

Offset link

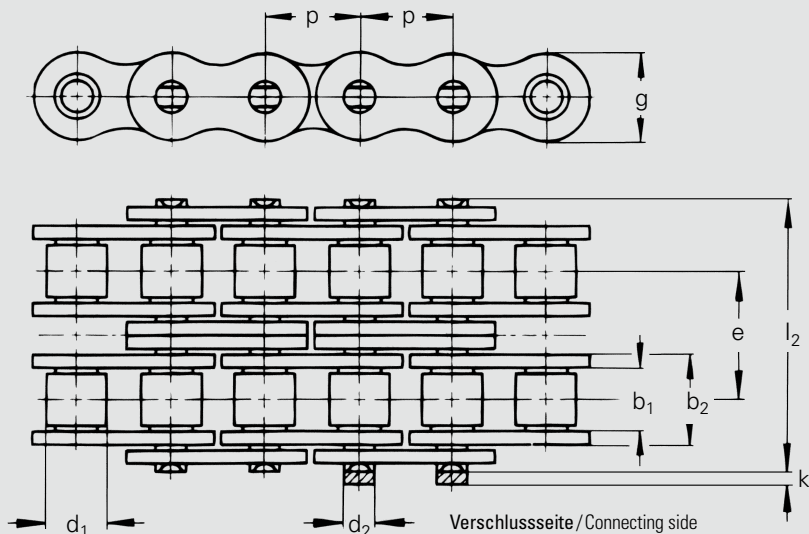

WITRA® No.	Teilung Pitch p		Innere Breite Inner width b_1 min.	Innen- glied- breite Inner link width b_2 max.	Rollen- Ø Roller- Ø d_1 min.	Bolzen- Ø Pin- Ø d_2 max.	Quer- teilung Trans- verse pitch e	Laschen- höhe Plate height g max.	Über- stand Project. over conn. link k max.	Maß über Bolzen Width over pin l_2 max.	Gelenk- fläche Bear- ing area f	Bruchkraft DIN Breaking load DIN F_B min.	Gewicht Weight q \approx	Verbindungs- glieder Connecting links Type
	mm	inch	mm	mm	mm	mm	mm	mm	mm	mm	cm ²	N	kg/m	
WT ASA 60-H-2	19,05	¾	12,57	19,43	11,91	5,96	26,11	18,1	4,6	56,3	2,27	62 600	3,71	A, E, L
WT ASA 80-H-2	25,4	1	15,75	24,28	15,88	7,94	32,59	24,1	5,4	70,0	3,79	112 200	5,93	A, S, L
WT ASA 100-H-2	31,75	1¼	18,90	29,10	19,05	9,54	39,09	30,2	6,1	83,6	5,50	174 000	8,67	A, S, L
WT ASA 120-H-2	38,1	1½	25,22	37,18	22,23	11,11	48,87	36,2	6,6	103,9	8,20	250 000	13,13	A, S, L
WT ASA 140-H-2	44,45	1¾	25,22	38,86	25,40	12,71	52,20	42,2	7,4	111,2	9,35	340 000	16,51	A, S, L
WT ASA 160-H-2	50,8	2	31,55	46,88	28,58	14,29	61,90	48,3	7,9	131,3	12,77	446 000	21,32	A, S, L

Verbindungsglieder / Connecting links

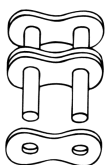

A

Außenglied
(Nietglied)

Pin link



E

Verbindungsglied
mit Feder

Spring
Connecting link

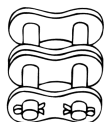

S

Verbindungsglied
mit Splinten

Cotter pin
Connecting link



L

Gekröpftes Glied
mit Splint

Offset link

Rollenketten „rostfrei“ - Rollenketten Reihe C „rostfrei“

Roller chains „stainless steel“ - Roller chains with straight side plates „stainless steel“

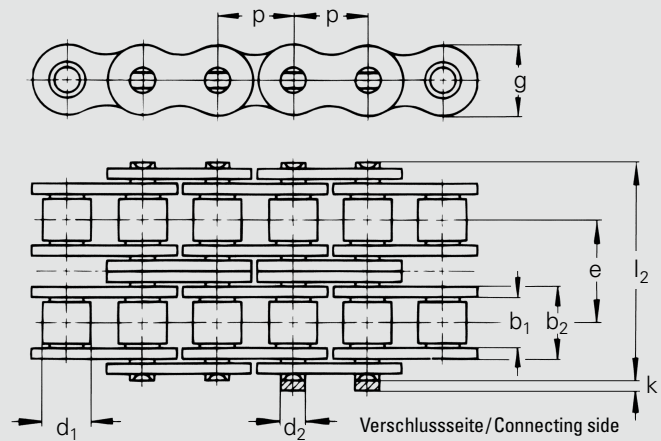
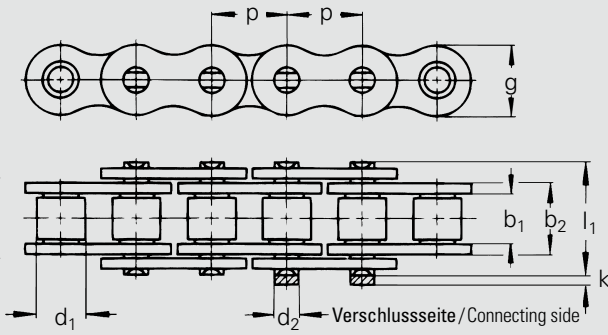

WITRA [®]	DIN / ISO	Teilung		Innere Breite	Innengliedbreite	Rollen-Ø	Bolzen-Ø	Quer-teilung	Laschen-höhe	Über-stand	Maß über Bolzen	Gelenk-fläche	Bruch-kraft DIN	Gewicht	Verbindungs-glieder
No.	No.	mm	inch	mm	mm	mm	mm	mm	mm	mm	mm	cm ²	N	kg/m	Connecting links
		Pitch		Inner width	Inner link width	Roller-Ø	Pin-Ø	Transverse pitch	Plate height	Project. over conn. link	Width over pin	Bearing area	Breaking load DIN	Weight	Connecting links
		p		b ₁ min.	b ₂ max.	d ₁ min.	d ₂ max.	e	g max.	k max.	l max.	f	F _B min.	q ≈	Type
WT 05 SS	05 B-1	8	-	3,00	4,77	5,00	2,31	-	7,1	3,1	8,6	0,11	5 000	0,18	A, E, C
WT 06 SS	06 B-1	9,525	3/8	5,72	8,53	6,35	3,28	-	8,2	3,3	13,5	0,28	9 000	0,41	A, E, L, C
WT 08 SS	08 B-1	12,7	1/2	7,75	11,30	8,51	4,45	-	11,8	3,9	17,0	0,50	12 000	0,68	A, E, L, C
WT 10 SS	10 B-1	15,875	5/8	9,65	13,28	10,16	5,08	-	14,7	4,1	19,6	0,67	15 000	0,91	A, E, L, C
WT 12 SS	12 B-1	19,05	3/4	11,68	15,62	12,07	5,72	-	16,1	4,6	22,7	0,88	17 000	1,12	A, E, L, C
WT 16 SS	16 B-1	25,4	1	17,02	25,40	15,88	8,27	-	21,0	5,4	36,1	2,07	40 000	2,64	A, E, L, C
WT 06-D SS	06 B-2	9,525	3/8	5,72	8,53	6,35	3,28	10,24	8,2	3,3	23,8	0,56	16 900	0,78	A, E, L, C
WT 08-D SS	08 B-2	12,7	1/2	7,75	11,30	8,51	4,45	13,92	11,8	3,9	31,0	1,00	22 000	1,35	A, E, L, C
WT 10-D SS	10 B-2	15,875	5/8	9,65	13,28	10,16	5,08	16,59	14,7	4,1	36,2	1,34	28 400	1,79	A, E, L, C
WT 12-D SS	12 B-2	19,05	3/4	11,68	15,62	12,07	5,72	19,46	16,1	4,6	42,2	1,76	37 200	2,22	A, E, L, C
WT 16-D SS	16 B-2	25,4	1	17,02	25,40	15,88	8,27	31,88	21,0	5,4	68,0	4,14	74 400	5,13	A, E, L, C

Einfach Rollenketten Reihe C „rostfrei“ (gerade Laschen) Simplex roller chains with straight side plates „stainless steel“

WT C 08 SS	08 B-1	12,7	1/2	7,75	11,30	8,51	4,45	-	11,8	3,9	17,0	0,50	12 000	0,68	A, E, L
WT C 10 SS	10 B-1	15,875	5/8	9,65	13,28	10,16	5,08	-	14,7	4,1	19,1	0,67	15 000	0,91	A, E, L
WT C 12 SS	12 B-1	19,05	3/4	11,68	15,62	12,07	5,72	-	16,1	4,6	22,7	0,88	17 000	1,12	A, E, L
WT C 16 SS	16 B-1	25,4	1	17,02	25,40	15,88	8,27	-	21,0	5,4	36,1	2,07	40 000	2,64	A, E, L
WT C 16 SS/24	-	25,4	1	17,02	25,40	15,88	8,27	-	24,0	5,4	36,1	2,07	40 000	2,64	A, E, L

Verbindungsglieder / Connecting links

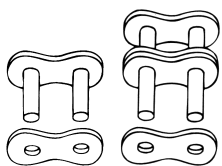

A
Außenglied
(Nietglied)

Pin link

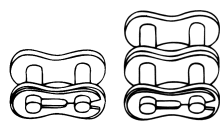

E
Verbindungsglied
mit Feder

Spring
Connecting link

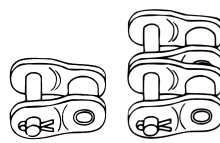

L
Gekröpftes Glied
mit Splint

Offset link

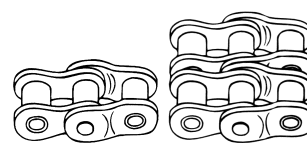

C
Gekröpftes
Doppelglied

Double
cranked link

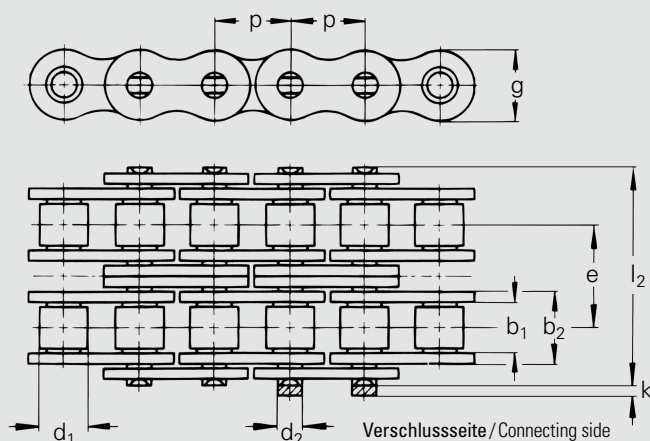
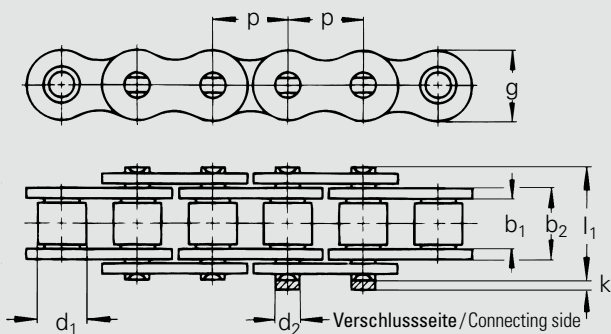

WITRA®	DIN/ISO	Teilung		Innere Breite	Innengliedbreite	Rollen-Ø	Bolzen-Ø	Quer- teilung	Laschen- höhe	Über- stand	Maß über Bolzen	Gelenk- fläche	Bruch- kraft DIN	Gewicht	Verbindungs- glieder
		Pitch		Inner width	Inner link width	Roller- Ø	Pin- Ø	Trans- verse pitch	Plate height	Project. over conn. link	Width over pin	Bear- ing area	Breaking load DIN	Weight	Connecting links
		p		b ₁ min.	b ₂ max.	d ₁ min.	d ₂ max.	e	g max.	k max.	l max.	f	F _B min.	q ≈	
No.	No.	mm	inch	mm	mm	mm	mm	mm	mm	mm	mm	cm ²	N	kg/m	Type
WT 05 NP	05 B-1	8	-	3,00	4,77	5,00	2,31	-	7,1	3,1	8,6	0,11	5 000	0,18	A, E
WT 06 NP	06 B-1	9,525	3/8	5,72	8,53	6,35	3,28	-	8,2	3,3	13,5	0,28	9 000	0,39	A, E, L
WT 08 NP	08 B-1	12,7	1/2	7,75	11,30	8,51	4,45	-	11,8	3,9	17,0	0,50	18 000	0,68	A, E, L
WT 10 NP	10 B-1	15,875	5/8	9,65	13,28	10,16	5,08	-	14,7	4,1	19,6	0,67	22 400	0,91	A, E, L
WT 12 NP	12 B-1	19,05	3/4	11,68	15,62	12,07	5,72	-	16,1	4,6	22,7	0,89	29 000	1,12	A, E, L
WT 16 NP	16 B-1	25,4	1	17,02	25,40	15,88	8,28	-	21,0	5,4	36,1	2,10	60 000	2,64	A, E, L
WT 05-D NP	05 B-2	8	-	3,00	4,77	5,00	2,31	5,64	7,1	3,1	14,3	0,22	7 800	0,36	A, E
WT 06-D NP	06 B-2	9,525	3/8	5,72	8,53	6,35	3,28	10,24	8,2	3,3	23,8	0,56	16 900	0,74	A, E, L
WT 08-D NP	08 B-2	12,7	1/2	7,75	11,30	8,51	4,45	13,92	11,8	3,9	31,0	1,01	32 000	1,35	A, E, L
WT 10-D NP	10 B-2	15,875	5/8	9,65	13,28	10,16	5,08	16,59	14,7	4,1	36,2	1,34	44 500	1,79	A, E, L
WT 12-D NP	12 B-2	19,05	3/4	11,68	15,62	12,07	5,72	19,46	16,1	4,6	42,2	1,79	57 800	2,22	A, E, L
WT 16-D NP	16 B-2	25,4	1	17,02	25,40	15,88	8,28	31,88	21,0	5,4	68,0	4,21	106 000	5,13	A, E, L

Verbindungsglieder / Connecting links

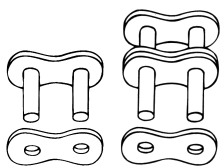

A
Außenglied
(Nietglied)

Pin link

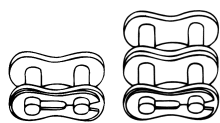

E
Verbindungsglied
mit Feder

Spring
Connecting link

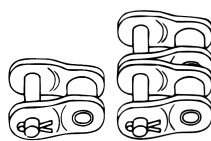

L
Gekrüptes Glied
mit Splint

Offset link

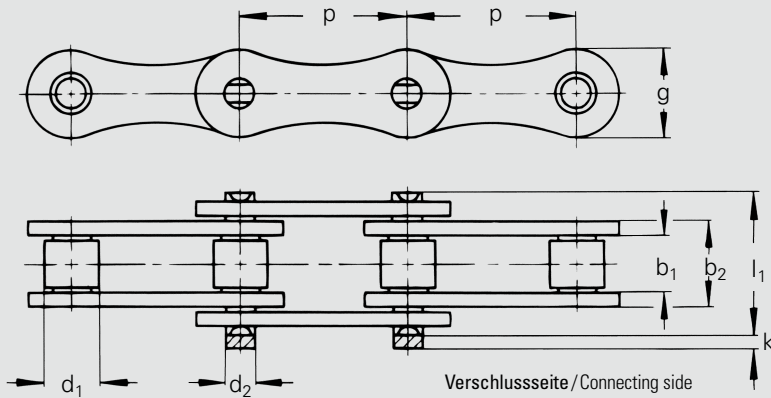

WITRA [®]	DIN/ISO	Teilung		Innere Breite	Innengliedbreite	Rollen-Ø	Bolzen-Ø	Laschenhöhe	Überstand	Maß über Bolzen	Gelenkfläche	Bruchkraft DIN	Gewicht	Verbindungsglieder
		Pitch	Pitch											
No.	No.	mm	inch	b ₁ min.	b ₂ max.	d ₁ min.	d ₂ max.	g max.	k max.	l ₁ max.	f	F _B min.	q ≈	Type
Amerikanische Bauart / American Series														
WT 208-A	208-A	25,4	1	7,85	11,15	7,95	3,96	12,0	3,9	17,8	0,44	14 100	0,49	A, B, S, L
WT 210-A	210-A	31,75	1 ¼	9,40	13,80	10,16	5,08	15,0	4,1	21,8	0,70	22 200	0,64	A, B, S, L
WT 212-A	212-A	38,1	1 ½	12,57	17,70	11,91	5,94	18,0	4,6	26,9	1,05	31 800	1,02	A, B, S, L
WT 216-A	216-A	50,8	2	15,75	22,50	15,88	7,92	24,1	5,4	33,5	1,78	56 700	1,71	A, B, S, L
WT 220-A	220-A	63,5	2 ½	18,90	27,40	19,05	9,53	30,0	4,3	40,4	2,59	86 700	2,55	A, B, S, L
Europäische Bauart / European Series														
WT 208-B	208-B	25,4	1	7,75	11,30	8,51	4,45	11,8	3,9	17,0	0,50	18 000	0,46	A, B, S, L
WT 210-B	210-B	31,75	1 ¼	9,65	13,28	10,16	5,08	14,7	4,1	19,6	0,67	22 400	0,57	A, B, S, L
WT 212-B	212-B	38,1	1 ½	11,68	15,62	12,07	5,72	16,1	4,6	22,7	0,89	29 000	0,75	A, B, S, L
WT 216-B	216-B	50,8	2	17,02	25,40	15,88	8,28	21,0	5,4	36,1	2,10	60 000	1,74	A, B, S, L
WT 220-B	220-B	63,5	2 ½	19,56	29,00	19,05	10,19	28,5	6,1	43,2	2,96	95 000	2,55	A, B, S, L

Verbindungsglieder / Connecting links

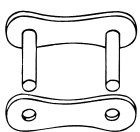

A

Außenglied
(Nietglied)

Pin link

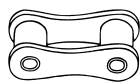

B

Innenglied

Inner link

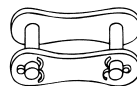

S

Verbindungsglied
mit Splinten

Cotter pin
Connecting link

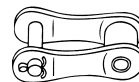

L

Gekröpftes Glied
mit Splint

Offset link

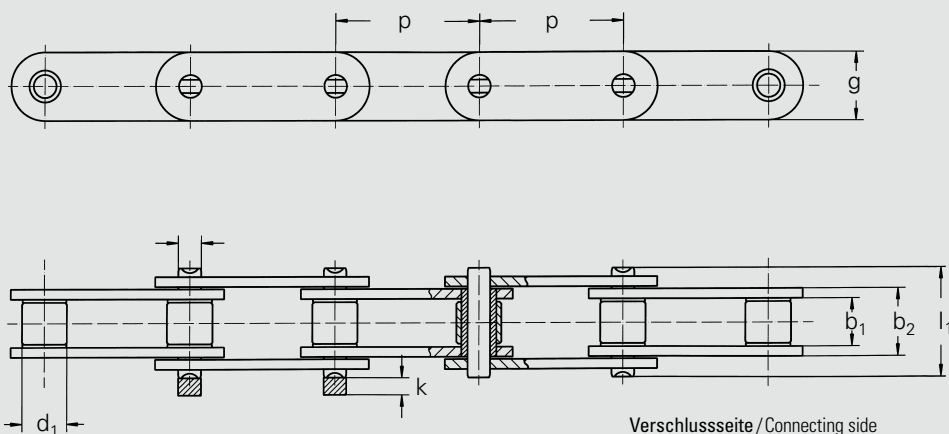

WITRA®	DIN/ISO	Teilung		Innere Breite	Innengliedbreite	Rollen-Ø	Bolzen-Ø	Laschenhöhe	Überstand	Maß über Bolzen	Gelenkfläche	Bruchkraft DIN	Gewicht	Verbindungs-glieder
		Pitch		Inner width	Inner link width	Roller-Ø	Pin-Ø	Plate height	Project. over conn. link	Width over pin	Bearing area	Breaking load DIN	Weight	Connecting links
		p		b ₁ min.	b ₂ max.	d ₁ min.	d ₂ max.	g max.	k max.	l ₁ max.	f	F _B min.	q ≈	
No.	No.	mm	inch	mm	mm	mm	mm	mm	mm	mm	cm ²	N	kg/m	Type
WT C 2050	C 210A	31,75	1 ¼	9,40	13,84	10,16	5,09	15,1	4,1	21,8	0,70	21 800	0,81	A, B, S, L
WT C 2060-H	C 212A-H	38,1	1 ½	12,57	19,43	11,91	5,96	18,1	4,6	29,8	1,16	31 100	1,87	A, B, S, L

Hohlbolzenkette

Hollow Pin chain

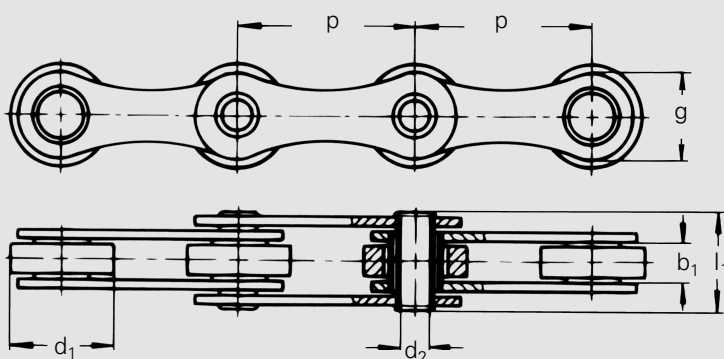

WITRA®	Teilung		Innere Breite	Rollen-Ø	Bohrungs-Ø	Laschenhöhe	Hohlbolzenbreite	Gelenkfläche	Bruchkraft DIN	Gewicht
	Pitch		Inner width	Roller-Ø	Bore Ø	Plate height	Hollow pin width	Bearing area	Breaking load DIN	Weight
	p		b ₁ min.	d ₁ min.	d ₂ max.	g max.	l ₁ max.	f	F _B min.	q ≈
No.	mm	inch	mm	mm	mm	mm	mm	cm ²	N	kg/m
WT 01650	50,8	2	10,00	30,00	8,20	26,0	27,0	1,94	50 000	2,15

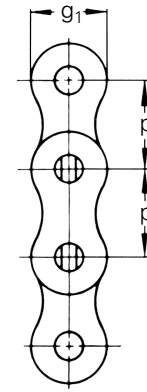
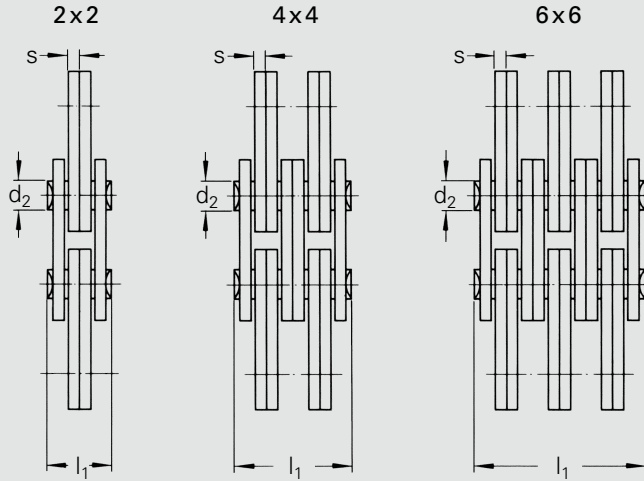

WITRA [®]	DIN/ISO ANSI	Nennteilung Pitch	Laschen- kombination Lacing	Laschenhöhe Plate height	Laschendicke Plate thickness	Bolzen- Ø Pin- Ø	Breite über Bolzen Width over pin	Bruchkraft Breaking load	Gewicht Weight
		p		g ₁ max.	s	d ₂ max.	l ₁ max.	F _B min.	q ≈
No.	No.	mm		mm	mm	mm	mm	N	kg/m
WT LL0822	LL0822	12,7	2 x 2	10,6	1,60	4,45	7,9	17 800	0,41
WT LL0844	LL0844	12,7	4 x 4	10,6	1,60	4,45	14,4	31 100	0,69
WT LL0866	LL0866	12,7	6 x 6	10,6	1,60	4,45	20,5	44 500	0,97
WT LL1022	LL1022	15,875	2 x 2	13,7	1,65	5,08	9,3	22 200	0,59
WT LL1044	LL1044	15,875	4 x 4	13,7	1,65	5,08	16,1	44 500	1,13
WT LL1066	LL1066	15,875	6 x 6	13,7	1,65	5,08	22,9	66 700	1,67
WT LL1222	LL1222	19,05	2 x 2	15,0	1,85	5,72	10,7	28 900	0,64
WT LL1244	LL1244	19,05	4 x 4	15,0	1,85	5,72	18,5	57 800	1,26
WT LL1266	LL1266	19,05	6 x 6	15,0	1,85	5,72	26,3	86 700	1,88
WT LL1622	LL1622	25,4	2 x 2	21,0	3,20	8,28	17,2	58 000	1,52
WT LL1644	LL1644	25,4	4 x 4	21,0	3,20	8,28	30,2	116 000	2,98
WT LL1666	LL1666	25,4	6 x 6	21,0	3,20	8,28	43,2	174 000	4,44
WT LL2022	LL2022	31,75	2 x 2	26,4	3,70	10,19	20,1	95 000	2,33
WT LL2044	LL2044	31,75	4 x 4	26,4	3,70	10,19	35,1	190 000	4,56
WT LL2066	LL2066	31,75	6 x 6	26,4	3,70	10,19	50,1	285 000	6,79
WT LL2422	LL2422	38,1	2 x 2	33,2	5,20	14,63	28,4	170 000	4,47
WT LL2444	LL2444	38,1	4 x 4	33,2	5,20	14,63	49,4	340 000	8,67
WT LL2466	LL2466	38,1	6 x 6	33,2	5,20	14,63	70,4	510 000	12,87

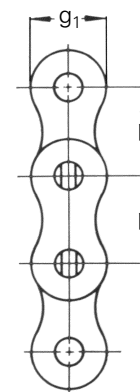
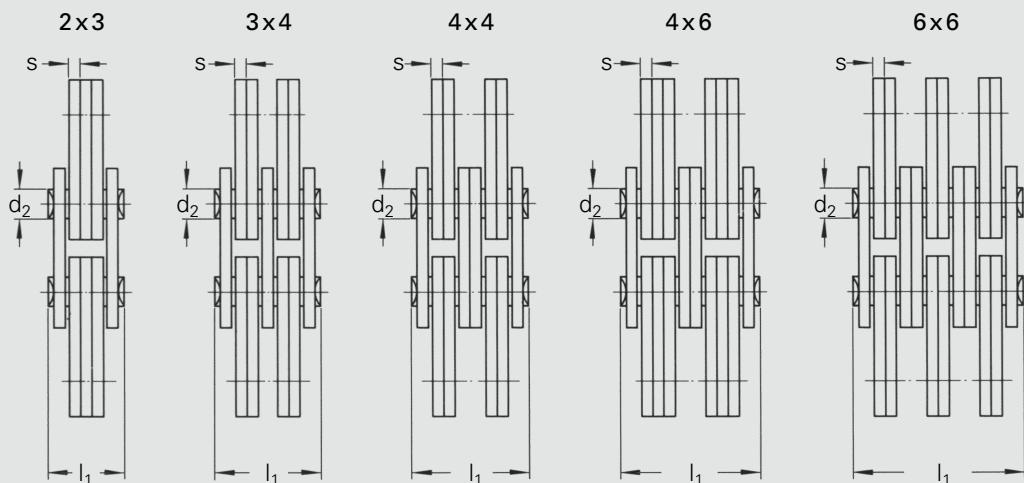

WITRA®	DIN/ISO ANSI	Nennteilung Pitch	Laschen- kombination Lacing	Laschenhöhe Plate height	Laschendicke Plate thickness	Bolzen- Ø Pin- Ø	Breite über Bolzen Width over pin	Bruchkraft Breaking load	Gewicht Weight
		p		g ₁ max.	s	d ₂ max.	l ₁ max.	F _B min.	q ≈
No.	No.	mm		mm	mm	mm	mm	N	kg/m
WT BL0523	LH1023	15,875	2 x 3	15,0	2,42	5,94	15,37	33 400	1,16
WT BL0534	LH1034	15,875	3 x 4	15,0	2,42	5,94	20,32	48 900	1,62
WT BL0544	LH1044	15,875	4 x 4	15,0	2,42	5,94	22,78	66 700	1,84
WT BL0546	LH1046	15,875	4 x 6	15,0	2,42	5,94	27,74	66 700	2,30
WT BL0566	LH1066	15,875	6 x 6	15,0	2,42	5,94	32,18	100 100	2,74
WT BL0623	LH1223	19,05	2 x 3	18,0	3,25	7,92	20,73	48 900	1,80
WT BL0634	LH1234	19,05	3 x 4	18,0	3,25	7,92	27,43	75 600	2,49
WT BL0644	LH1244	19,05	4 x 4	18,0	3,25	7,92	30,78	97 900	2,83
WT BL0646	LH1246	19,05	4 x 6	18,0	3,25	7,92	37,49	97 900	3,52
WT BL0666	LH1266	19,05	6 x 6	18,0	3,25	7,92	44,20	148 800	4,21
WT BL0688	LH1288	19,05	8 x 8	18,0	3,25	7,92	57,61	195 700	5,60

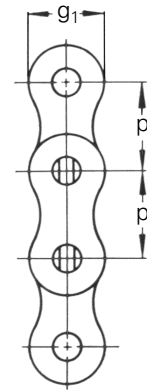
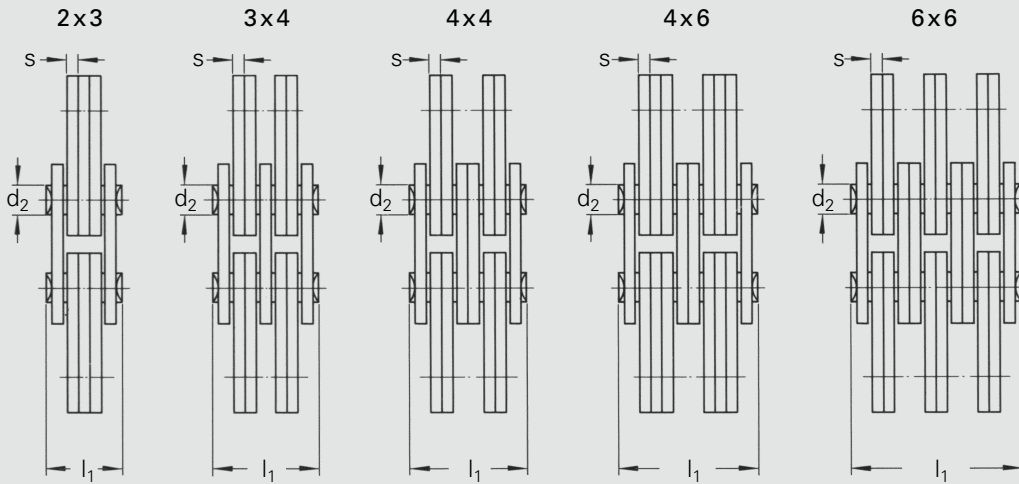

WITRA [®]	DIN/ISO ANSI	Nennteilung Pitch	Laschen- kombination Lacing	Laschenhöhe Plate height	Laschendicke Plate thickness	Bolzen- Ø Pin- Ø	Breite über Bolzen Width over pin	Bruchkraft Breaking load	Gewicht Weight
No.	No.	mm		mm	mm	mm	mm	N	kg/m
WT BL0823	LH1623	25,4	2 x 3	24,0	4,00	9,53	25,48	84 500	3,47
WT BL0834	LH1634	25,4	3 x 4	24,0	4,00	9,53	33,76	129 000	4,82
WT BL0844	LH1644	25,4	4 x 4	24,0	4,00	9,53	37,90	169 000	5,43
WT BL0846	LH1646	25,4	4 x 6	24,0	4,00	9,53	46,18	169 000	6,83
WT BL0866	LH1666	25,4	6 x 6	24,0	4,00	9,53	54,46	253 600	8,19
WT BL1023	LH2023	31,75	2 x 3	30,0	4,80	11,10	30,33	115 600	4,65
WT BL1034	LH2034	31,75	3 x 4	30,0	4,80	11,10	40,23	182 400	6,46
WT BL1044	LH2044	31,75	4 x 4	30,0	4,80	11,10	45,19	231 300	7,37
WT BL1046	LH2046	31,75	4 x 6	30,0	4,80	11,10	55,09	231 300	9,18
WT BL1066	LH2066	31,75	6 x 6	30,0	4,80	11,10	65,00	347 000	11,00

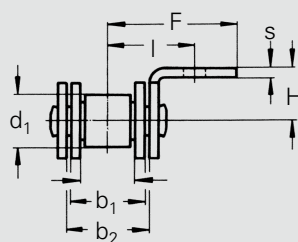
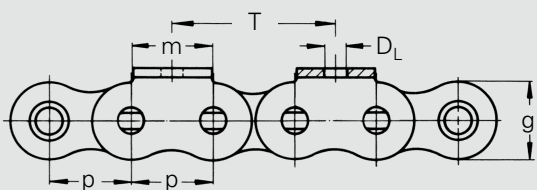

A

einseitige Winkelaschen

bent attachments,
one side

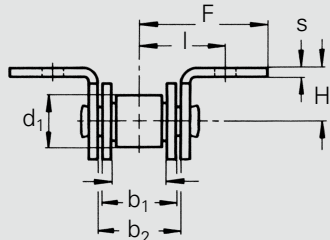
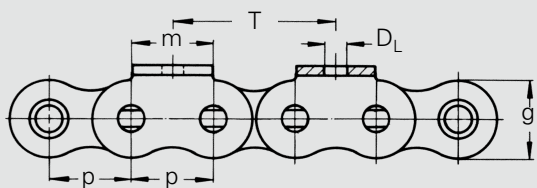

B

zweiseitige Winkelaschen

bent attachments,
both side

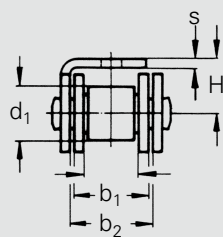
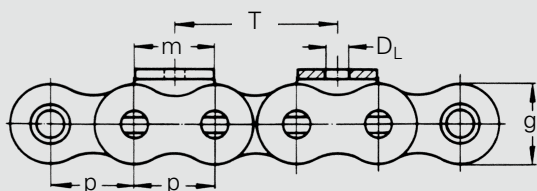

C

**Winkelaschen einseitig
übergreifend**

bent over chain
attachments, one side

WITRA®		Similar DIN/ISO	Nennteilung		Innere Breite	Innen- glied- breite	Rollen- Ø	Laschen- höhe	Bruch- kraft	Mitnehmer-Maße					
			Pitch		Inner width	Inner link width	Roller- Ø	Plate height	Breaking load DIN	Attachment dimensions					
			p		b ₁ min.	b ₂ max.	d ₁ min.	g max.	F _B min.	m	D _L	I	F	H	s
No.	Ind.	No.	mm	inch	mm	mm	mm	mm	N	mm	mm	mm	mm	mm	mm
WT 05		05 B-1	8		3,00	4,77	5,00	7,1	5 000	8,0	3,20	6,6	12,0	5,0	0,80
WT 06	¹	06 B-1	9,525	3/8	5,72	8,53	6,35	8,2	9 000	8,0	3,50	9,5	13,5	6,5	1,25
WT 08		08 B-1	12,7	1/2	7,75	11,30	8,51	11,8	18 000	12,5	4,50	13,1	19,0	10,0	1,50
WT 10		10 B-1	15,875	5/8	9,65	13,28	10,16	14,7	22 400	15,0	5,50	16,7	27,0	10,0	1,70
WT 12		12 B-1	19,05	3/4	11,68	15,62	12,07	16,1	29 000	18,5	6,60	18,6	29,0	11,0	1,80
WT 16		16 B-1	25,4	1	17,02	25,40	15,88	21,0	60 000	25,0	9,00	28,9	41,8	18,0	3,00
WT 20		20 B-1	31,75	1 1/4	19,56	29,00	19,05	26,4	95 000	35,0	9,00	33,4	50,0	18,0	3,75
WT 24		24 B-1	38,1	1 1/2	25,40	37,90	25,40	33,4	160 000	38,0	11,00	44,0	64,0	25,0	5,00

¹ nur mit geraden Laschen / ¹ with straight side plates only

Rollenketten mit Flachlaschen und Mitnehmerbolzen

Roller chains with single hole straight attachments and extended pins

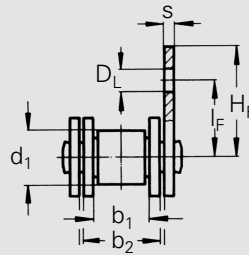
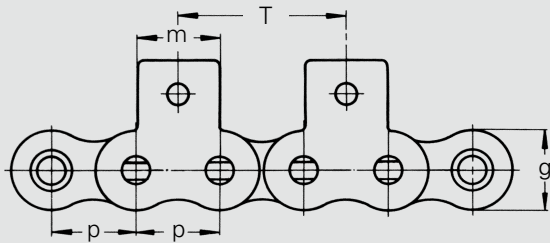

D

einseitige Flachlaschen

straight attachments,
one side

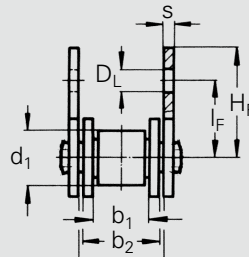
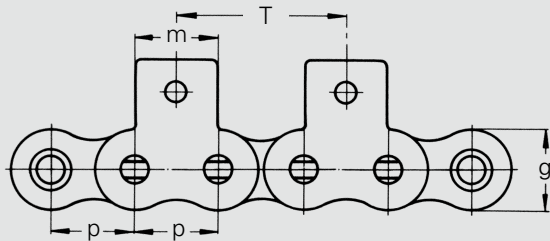

E

zweiseitige Flachlaschen

straight attachments,
both sides

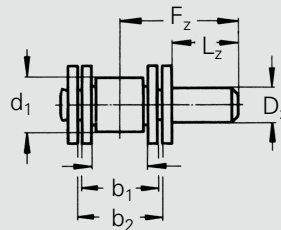
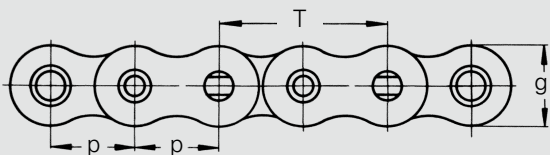

F

**einseitige Mitnehmerbolzen
(auch versetzt wechselseitig
möglich)**

extended pins, available
on alternate sides

WITRA [®]		Similar DIN / ISO	Nennteilung		Innere Breite	Innen- glied- breite	Rollen- Ø	La- schen- höhe	Bruch- kraft	Mitnehmer-Maße							
No.	Ind.	No.	Pitch		Inner width	Inner link width	Roller- Ø	Plate height	Breaking load DIN	Attachment dimensions							
			p		b ₁ min.	b ₂ max.	d ₁ min.	g max.	F _B min.	m	D _L	l _F	H _F	s	D _Z h9	L _Z	F _Z
			mm	inch	mm	mm	mm	mm	N	mm	mm	mm	mm	mm	mm	mm	mm
WT 05		05 B-1	8	-	3,00	4,77	5,00	7,1	5 000	8,0	3,00	7,5	13,0	0,80	4,0	10	13,3
WT 06	¹	06 B-1	9,525	3/8	5,72	8,53	6,35	8,2	9 000	8,0	3,50	9,0	13,8	1,25	5,0	15	20,7
WT 08		08 B-1	12,7	1/2	7,75	11,30	8,51	11,8	18 000	12,5	4,50	14,7	20,3	1,50	6,0	15	22,4
WT 10		10 B-1	15,875	5/8	9,65	13,28	10,16	14,7	22 400	15,0	5,50	17,2	26,7	1,70	6,5	20	28,5
WT 12		12 B-1	19,05	3/4	11,68	15,62	12,07	16,1	29 000	18,5	6,60	18,7	29,0	1,80	7,0	20	29,8
WT 16		16 B-1	25,4	1	17,02	25,40	15,88	21,0	60 000	25,0	9,00	28,6	41,5	3,00	10,0	30	45,9
WT 20		20 B-1	31,75	1 1/4	19,56	29,00	19,05	26,4	95 000	35,0	9,00	30,5	45,7	3,75	12,0	30	48,4
WT 24		24 B-1	38,1	1 1/2	25,40	37,90	25,40	33,4	160 000	38,0	11,00	41,0	60,0	5,00	16,0	35	59,1

¹ nur mit geraden Laschen / ¹ with straight side plates only

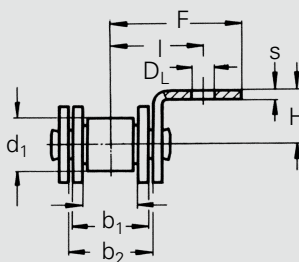
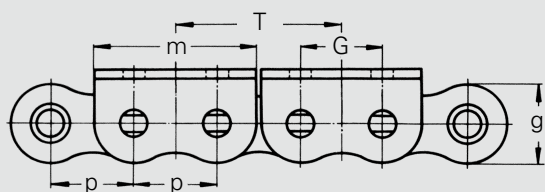

A2
einseitige Winkelaschen
bent attachments,
one side

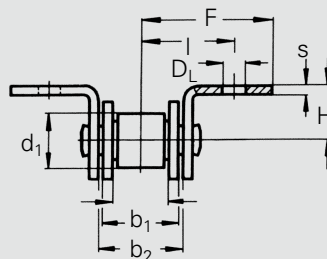
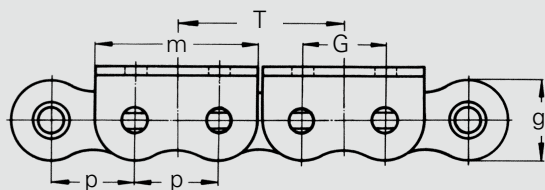

B2
zweiseitige Winkelaschen
bent attachments,
both side

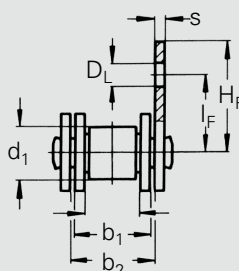
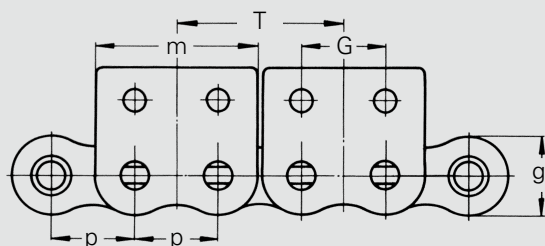

D2
einseitige Flachlaschen
straight attachments,
one side

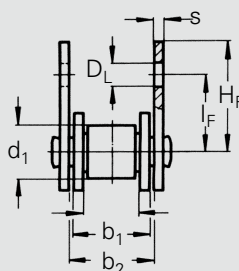
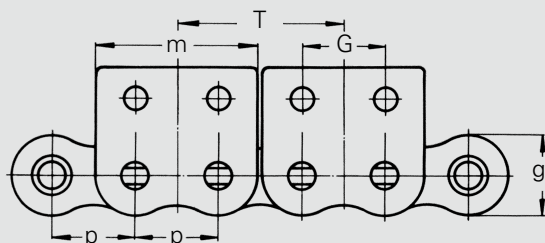

E2
zweiseitige Flachlaschen
straight attachments,
both sides

WITRA®		Similar DIN/ISO	Nennteilung		Innere Breite	Innen- glied- breite	Rollen- Ø	La- schen- höhe	Bruch- kraft DIN	Mitnehmer-Maße								
			Pitch		Inner width	Inner link width	Roller- Ø	Plate height	Breaking load DIN	Attachment dimensions								
			p		b ₁ min.	b ₂ max.	d ₁ min.	g max.	F _B min.	m	D _L	G	I	F	H	I _F	H _F	s
No.	Ind.	No.	mm	inch	mm	mm	mm	mm	N	mm	mm	mm	mm	mm	mm	mm	mm	mm
WT 06	¹	06 B-1	9,525	3/8	5,72	8,53	6,35	8,2	9 000	18,2	3,20	9,525	9,8	13,2	5,7	9,2	12,6	1,25
WT 08		08 B-1	12,7	1/2	7,75	11,30	8,51	11,8	18 000	23,2	4,50	12,7	13,1	19,0	10,0	14,7	20,3	1,50
WT 10		10 B-1	15,875	5/8	9,65	13,28	10,16	14,7	22 400	28,5	5,50	15,9	16,7	27,0	10,0	17,2	26,7	1,70
WT 12		12 B-1	19,05	3/4	11,68	15,62	12,07	16,1	29 000	33,6	6,60	19,1	18,6	29,0	11,0	18,7	29,0	1,80
WT 16		16 B-1	25,4	1	17,02	25,40	15,88	21,0	60 000	46,5	9,00	25,4	28,9	42,0	18,0	28,6	41,5	3,00
WT 20		20 B-1	31,75	1/4	19,56	29,00	19,05	26,4	95 000	55,7	9,00	31,75	33,4	50,0	18,0	30,5	45,7	3,75
WT 24		24 B-1	38,1	1/2	25,40	37,90	25,40	33,4	160 000	77,0	11,00	38,1	44,0	63,0	25,0	41,0	60,0	5,00

¹ nur mit geraden Laschen / ¹ with straight side plates only

Rollenketten „rostfrei“ mit breiten Winkel- und Flachlaschen

Roller chains „stainless steel“ with two hole bent and straight attachments

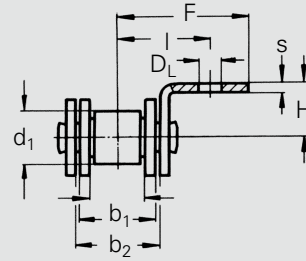
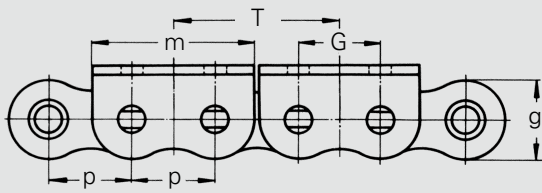

A2
einseitige Winkellaschen
bent attachments,
one side

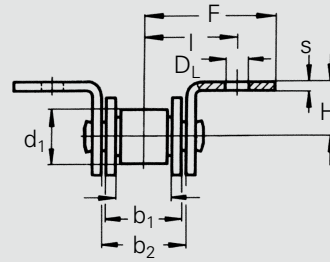
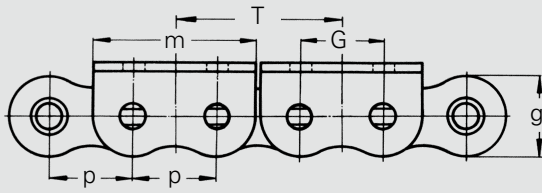

B2
zweiseitige Winkellaschen
bent attachments,
both side

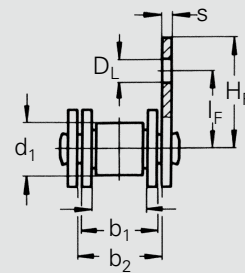
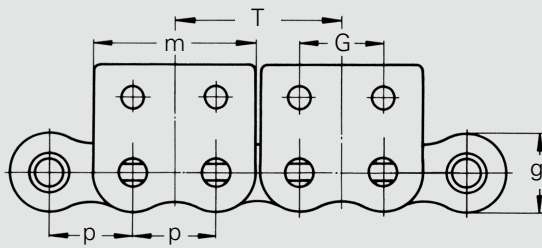

D2
einseitige Flachlaschen
straight attachments,
one side

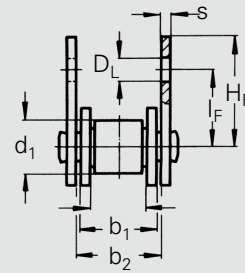
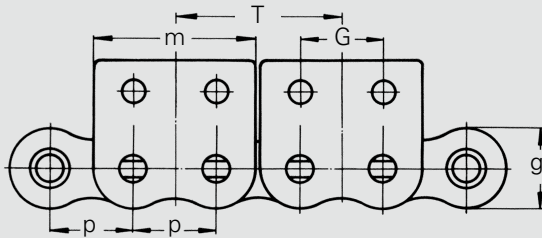

E2
zweiseitige Flachlaschen
straight attachments,
both sides

WITRA [®]		Similar DIN/ISO	Nennteilung		Innere Breite	Innen- glied- breite	Rollen- Ø	La- schen- höhe	Bruch- kraft DIN	Mitnehmer-Maße								
			Pitch		Inner width	Inner link width	Roller- Ø	Plate height	Breaking load DIN	Attachment dimensions								
			p		b ₁ min.	b ₂ max.	d ₁ min.	g max.	F _B min.	m	D _L	G	I	F	H	I _F	H _F	s
No.	Ind.	No.	mm	inch	mm	mm	mm	mm	N	mm	mm	mm	mm	mm	mm	mm	mm	mm
WT 06 SS	¹	06B-1	9,525	3/8	5,72	8,53	6,35	8,2	7 000	18,2	3,22	9,525	9,8	13,2	5,7	9,2	12,6	1,25
WT 08 SS		08B-1	12,7	1/2	7,75	11,30	8,51	11,8	12 000	23,2	4,50	12,7	13,1	19,0	10,0	14,7	20,3	1,60
WT 10 SS		10B-1	15,875	5/8	9,65	13,28	10,16	14,7	14 500	28,5	5,50	15,9	16,7	27,0	10,0	17,2	26,7	1,70
WT 12 SS		12B-1	19,05	3/4	11,68	15,62	12,07	16,1	18 500	33,6	6,60	19,1	18,5	29,0	11,0	18,7	29,0	1,80
WT 16 SS		16B-1	25,4	1	17,02	25,40	15,88	21,0	40 000	46,5	10,00	25,4	28,9	41,8	18,0	28,6	41,5	3,00

¹ nur mit geraden Laschen / ¹ with straight side plates only

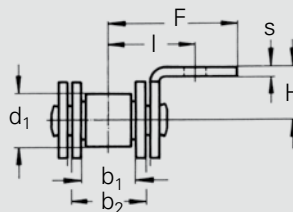
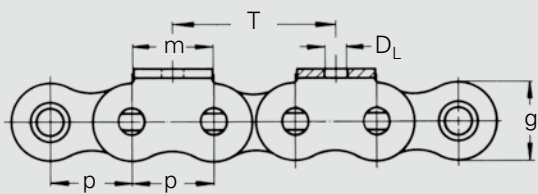

A
einseitige Winkellaschen
bent attachments,
one side

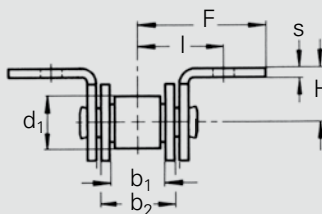
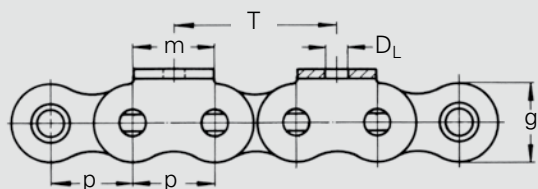

B
zweiseitige Winkellaschen
bent attachments,
both side

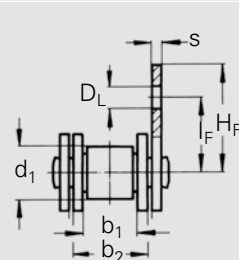
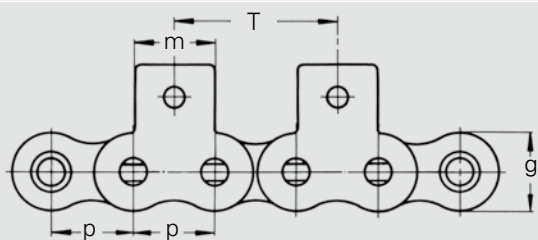

D
einseitige Flachlaschen
straight attachments,
one side

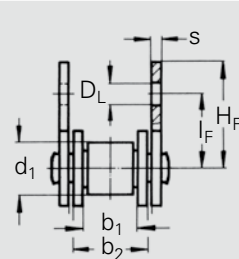
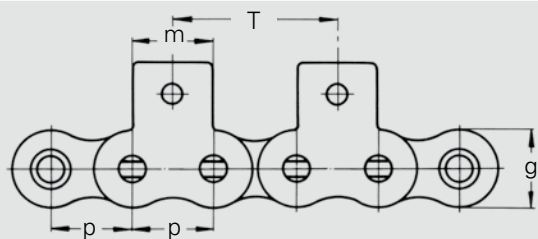

E
zweiseitige Flachlaschen
straight attachments,
both sides

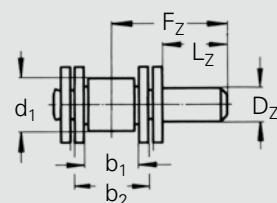
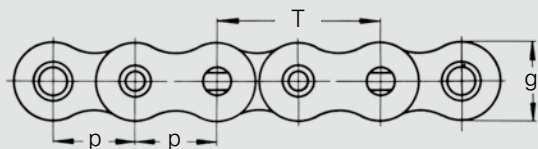

F
einseitige Mitnehmerbolzen
(auch versetzt wechselseitig
möglich)
extended pins, available
on alternate sides

WITRA®		Similar DIN/ISO	Teilung		Innere Breite		Innen- glied- breite		Rollen- Ø		La- schen- höhe		Mitnehmer-Maße							
No.	Ind.		Pitch		Inner width	Inner link width	Roller- Ø	Plate height	Attachment dimensions											
		p		b ₁ min.	b ₂ max.	d ₁ min.	g max.	m	D _L	l	F	H	l _F	H _F	s	D _Z h9	L _Z	F _Z		
		mm inch		mm	mm	mm	mm	mm	mm	mm	mm	mm	mm	mm	mm	mm	mm	mm		
WT 05 SS		05 B-1	8	-	3,00	4,77	5,00	7,1	8,0	3,20	6,6	12,0	5,0	7,5	13,0	0,80	4,0	10	13,3	
WT 06 SS	¹	06 B-1	9,525	3/8	5,72	8,53	6,35	8,2	8,0	3,50	9,5	13,5	6,5	9,0	13,4	1,25	5,0	15	20,7	
WT 08 SS		08 B-1	12,7	1/2	7,75	11,30	8,51	11,8	12,5	4,50	13,1	19,0	10,0	14,7	20,3	1,60	6,0	15	22,4	
WT 10 SS		10 B-1	15,875	5/8	9,65	13,28	10,16	14,7	15,0	5,50	16,7	27,0	10,0	17,2	26,7	1,70	6,5	20	28,5	
WT 12 SS		12 B-1	19,05	3/4	11,68	15,62	12,07	16,1	18,5	6,60	18,5	29,0	11,0	18,7	29,0	1,80	7,0	20	29,8	
WT 16 SS		16 B-1	25,4	1	17,02	25,40	15,88	21,0	25,0	10,00	28,9	41,5	18,0	41,8	28,6	3,00	10,0	30	45,9	

¹ nur mit geraden Laschen / ¹ with straight side plates only

Produktprogramm

Product range

Folgende Kettentypen sind ab Lager lieferbar:

- Rollenketten nach DIN
- Rollenketten nach ASA
- Rollenketten nach ASA verstärkt
- Rollenketten mit geraden Laschen
- Rollenketten aus rostfreiem Stahl
- Rollenketten in vernickelter Ausführung
- Flyerketten LL-Serie
- Flyerketten BL-Serie
- Rollenketten mit Mitnehmerlaschen

The following chain types are available in stock:

- Roller chains according to DIN
- Roller chains according to ASA
- Roller chains according to ASA (reinforced)
- Roller chains with straight side plates
- Roller chains made of stainless steel
- Nickel-plated roller chains
- Leaf chains type series LL
- Leaf chains type series BL
- Roller chains with attachment side plates

WIPPERMANN JR. GMBH TRADING

Im Obrock 153
32278 Kirchlengern

Tel.: +49 (0) 52 23-76 33-40

Fax: +49 (0) 52 23-76 33-48

witra@wippermann.com

witra.wippermann.com